



# Cavotec Metool – Australia



Newcastle, New South Wales



Perth, Western Australia



Melbourne, Victoria



Brisbane, Queensland

## CAVOTEC GROUP ORGANISATION 2001

### CAVOTEC MANUFACTURING

#### Motorised Cable Reels

Specimas - Italy & USA

Cavotec Metool - Australia

#### Panzerbelt® Cable Protection

Specimas - Italy & USA

#### Plugs & Sockets

Cavotec Connectors - Sweden

#### Spring Reels

Alfo Cavotec - Germany

Cavotec RMS - France

Cavotec Metool - Australia

#### Slipring Columns

Alfo Cavotec - Germany

Specimas - Italy & USA

#### Radio Remote Controls

Micro-control - Norway

GROUP PARTNER

#### Nylon & Steel Cable Chains

Brevetti Stendalto - Italy

GROUP PARTNER

#### Industrial Lifts

De Jong - Holland

GROUP PARTNER

### CAVOTEC SALES OFFICES

Cavotec Abu Dhabi

Cavotec Australia

Cavotec Bahrain

Cavotec BeNeLux

Cavotec China

Cavotec Denmark

Cavotec Finland

Cavotec France

Cavotec Germany

Cavotec Hong Kong

Cavotec Indonesia

Cavotec Italy

Cavotec Korea

Cavotec Latin America

Cavotec Middle East

Cavotec Norway

Cavotec Singapore

Cavotec Sweden

Cavotec UK & Ireland

Cavotec USA & Canada

### CAVOTEC KEY SUPPLIERS

#### Flexible Cables

Nexans - France

Pirelli

Baude - Germany & Australia

#### Crane Controllers

Gessmann - Germany

#### EEx-proof Slipring Columns

AC Smith - Norway

#### Electrical Connectors

TJB - USA

#### Rotating Connectors

Eletca - Italy

Mercotac - USA

#### Spreaders

Bromma Conquip - Sweden

#### Cable Ladders

Wibe - Sweden

#### Rail Clips

Gantrex - USA

The chart on this page shows how the Cavotec Group is organised to support its customers: on the left and in the centre, the Cavotec Group manufacturing and sales companies; on the right, the key suppliers. their combined technological competence and common approach to the market are the secret to the Cavotec Group's steady growth.

Some products of the Group key suppliers are not dealt by all Cavotec sales companies or distributors.

## CABLE TROLLEY

Ref: 2.337 - C - 5

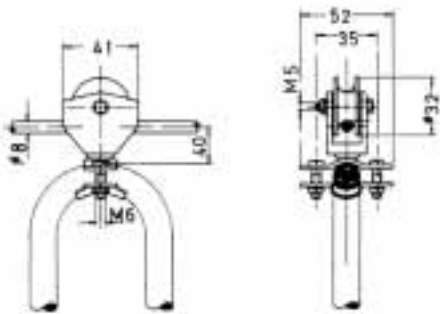

## CABLE TROLLEY

Ref: 2.337 - P - 5

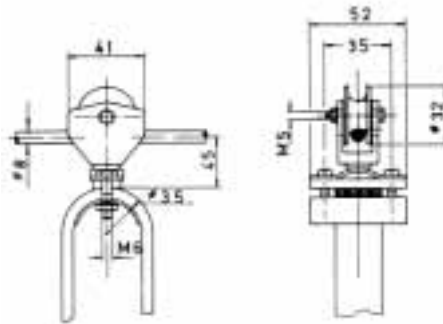

## CABLE TROLLEY

Ref: 2.337 - R - 5

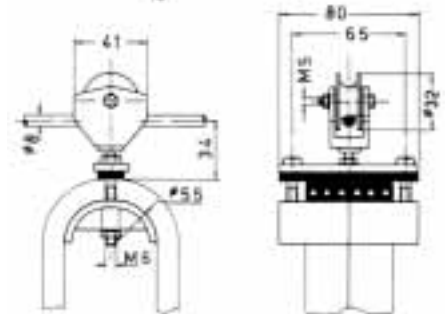

## END CLAMP

Ref: 2.337 - C - 6

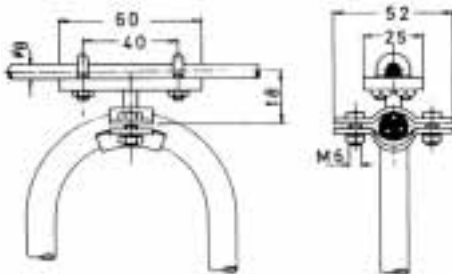

## END CLAMP

Ref: 2.337 - P - 2

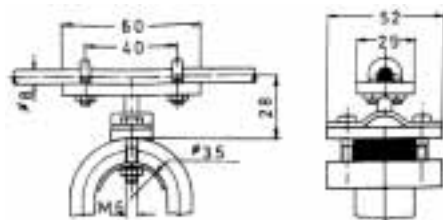

## END CLAMP

Ref: 2.337 - R - 2

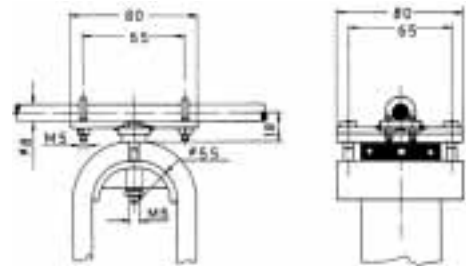

## TOWING TROLLEY

Ref: 2.337 - C - 6

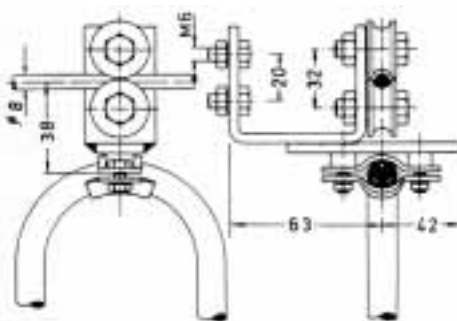

## TOWING TROLLEY

Ref: 2.337 - P - 6

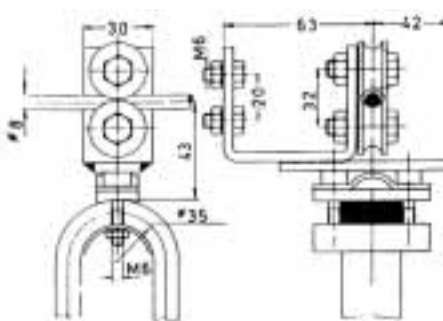

## TOWING TROLLEY

Ref: 2.337 - R - 6

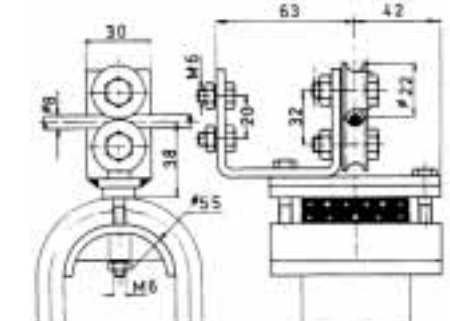

Run on steel rope  $\varnothing$  8mm. Maximum span width of installation = 20mm.

Load per trolley = 5kg.

Cable capacity:  $\varnothing$  8 to 15mm.

Body and wheel made of plastic.

Cable holder: galvanized steel.

When mounting, wind the conductor placing oneshank in each trolley to make easy a 90° rotation when parking. Finally clamp the conductor tight.

Load per trolley = 5kg.

Maximum bundle dimension: 29 x 8mm.

Body and wheel made of plastic.

Cable holder: galvanized steel.

Load per trolley = 5kg.

Maximum bundle dimension: 58 x 20mm.

Body, wheel and cable holder made of plastic.

Support plate: galvanized steel.

## CABLE TROLLEY

Ref: 2.337 – 2R – 5

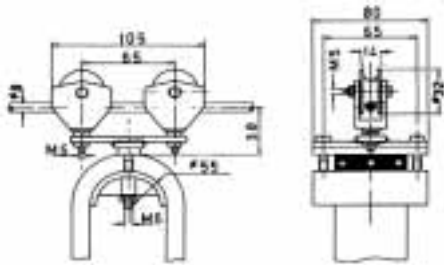

Ref: 2.337 – G

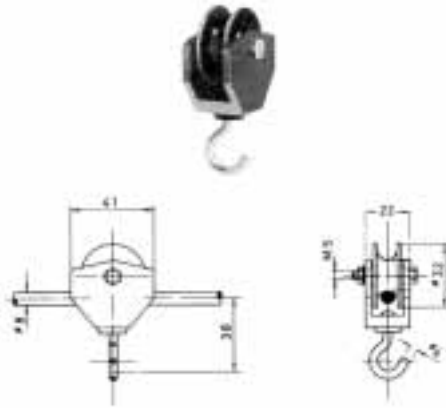

## END CLAMP

Ref: 2.337 – 2R – 2

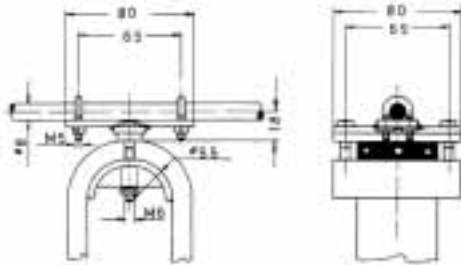

Advised for hanging tools and implements in mobile application.  
Body and wheel made of plastic.  
Hook: galvanized steel.

## TOWING TROLLEY

Ref: 2.337 – 2R – 6

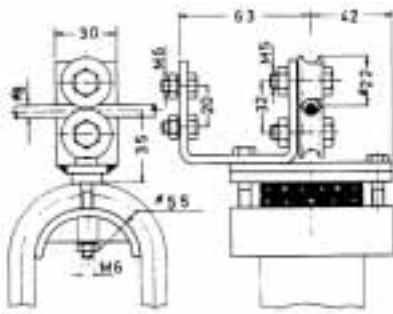

Load per trolley = 10kg.  
Maximum bundle dimension: 58 x 20mm.  
Body, wheel and cable holder made of plastic.  
Support plate: galvanized steel.

## CABLE TROLLEY

Ref: 2.344 - 1 - 1

Load per trolley: 30kg

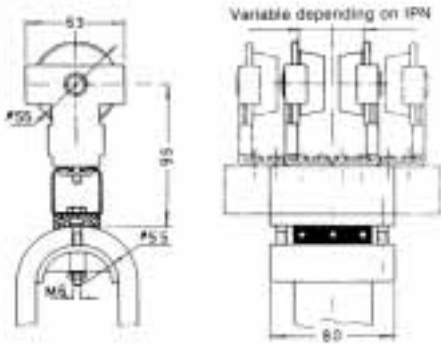

## CABLE TROLLEY

Ref: 2.344 - 1 - 2

Load per trolley: 30kg

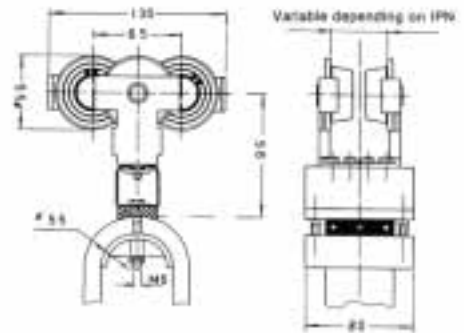

## END CLAMP

Ref: 2.344 - 2

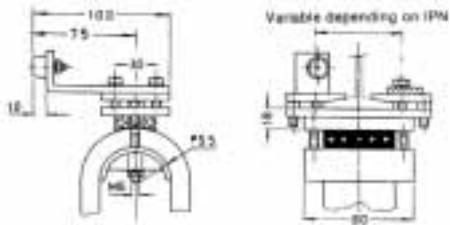

## TOWING TROLLEY

Ref: 2.344 - 6

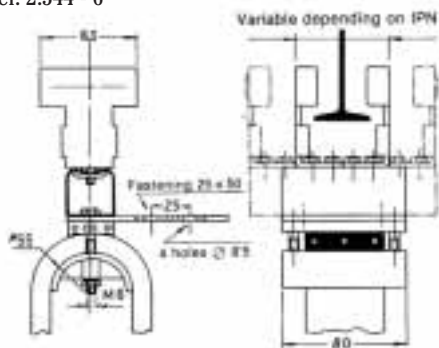

Maximum bundle dimension: 58 x 20mm.

Flat cables. These trolleys are advised for feeding hoists, sliding over the same hoist runway (indicate type and size).

Body made of galvanized steel. Wheels and cable holder: plastic. The piece which joins the support wheel and the cable holder, is supplied in different lengths, depending on the IPN size.

## CABLE TROLLEY

Ref: 2.344 - 2 - 2

Load per trolley: 60kg

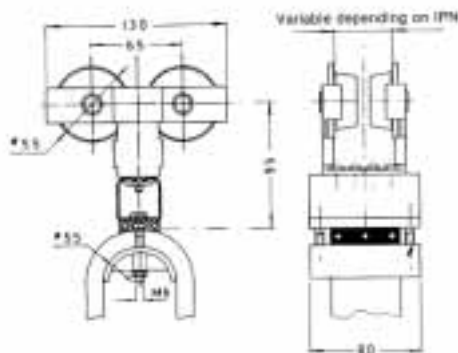

### Perth Office

82 Chisholm Crescent  
Kewdale 6105  
Western Australia  
Ph: 61 (08) 9453 3952  
Fax: 61 (08) 9453 3972

### Melbourne Office

Unit 2/483 Hammond Rd  
Dandenong 3175  
Victoria  
Ph: 61 (03) 9706 6788  
Fax: 61 (03) 9706 6789

### Newcastle Office

28 Mitchell Rd  
Cardiff 2285  
New South Wales  
Ph: 61 (02) 4956 5788  
Fax: 61 (02) 4956 5823

### Brisbane Office

30 Norbury Street  
Coopers Plains 4108  
Queensland  
Ph: 61 (07) 3277 6050  
Fax: 61 (07) 3255 6671

### Email

[sales@cavotecmetool.com.au](mailto:sales@cavotecmetool.com.au)

### World Wide Web

<http://www.cavotecmetool.com.au>

## TRACK PROFILE – 5 MTRS

Finish: Galvanized  
Weight: 1.280kg/m  
Part No: 100/5

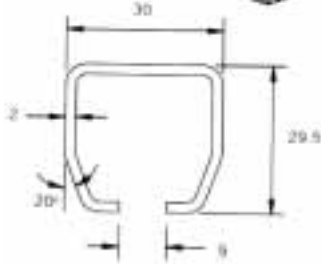

## SPLICE JOINT

Finish: Zinc Plated with Passivation  
Weight: 0.285kg  
Part No: 1103

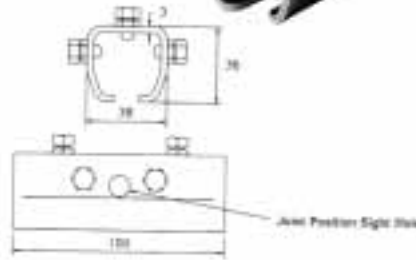

## CEILING SUPPORT BRACKET

WITH CLAMPING SCREW  
Finish: Zinc Plated with Passivation  
Weight: 0.185kg  
Part No: 102

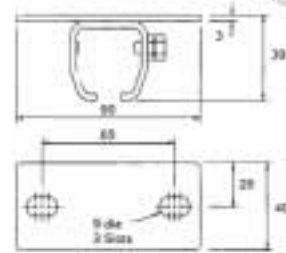

## END STOP

Finish: Zinc Plated with Passivation,  
rubber buffer  
Weight: 0.040kg  
Part No: 100P

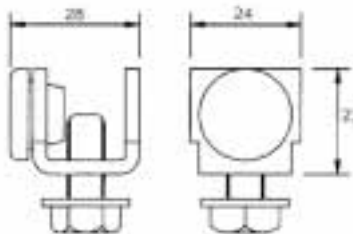

## END CAP

Finish: Black Nylon  
Weight: 0.005kg  
Part No: 100ECP

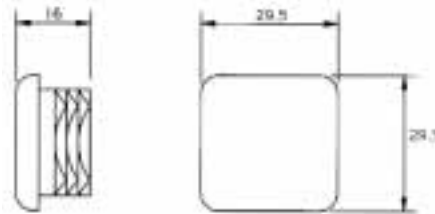

## FLAT CABLE TROLLEY

Finish: Chassis/Clamp – Black Polyamide  
Wheels – Acetal  
Axles & Clamp Screws –  
Steel, Zinc Plated

Weight: 0.125kg  
Part No: 100/50N

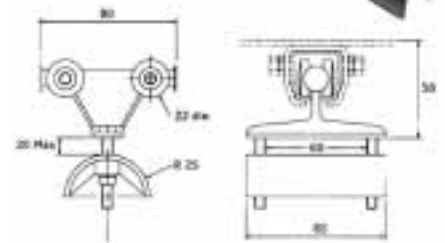

## TOWING ATTACHMENT

(SUPPLIED WITH PLATED ATTACHMENT SCREWS)

Finish: Moulded Black Polyamide or Steel  
Weight: 0.06kg – Nylon, 0.230kg – Steel  
Part No: 100TAN – Nylon  
100TAS – Steel, Zinc Plated with  
Passivation

A towing trolley is constructed by adding the towing attachment to a standard trolley, we recommend steel wheel trolleys only for this purpose.

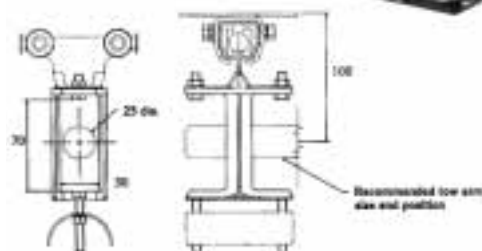

## END STOP/CLAMP

Finish: Chassis & Cable Support – Zinc plated  
with passivation Fasteners – Zinc  
Plated Buffer – Black Rubber

Weight: 0.235kg  
Part No: 100/137E

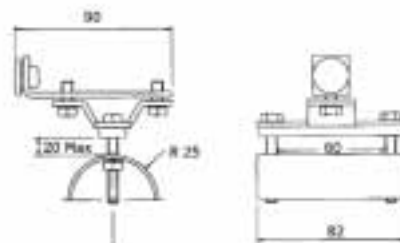

## FLAT CABLE TROLLEY

Finish: Chassis Clamp – Steel, Zinc plated  
with passivation  
Wheels – Steel, Zinc Plated Dustproof  
Axles & Clamp Screws – Steel, Zinc  
Plated

Weight: 0.250kg  
Part No: 100/137

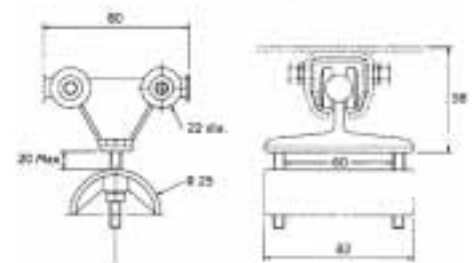

## END CLAMP

(LARGER CAPACITY)

Finish: Chassis – Grey Nylon  
Cable Support – Steel, Zinc Plated with Passivation  
Fasteners – Bright Zinc Plated

Weight: 0.320kg

Part No: 100/237E

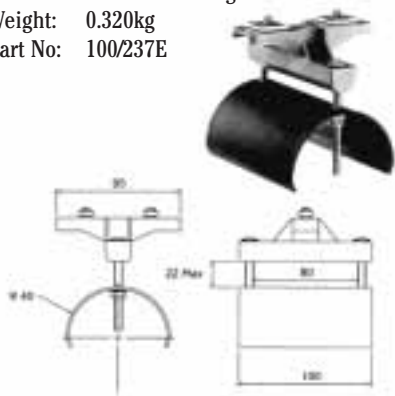

## FLAT CABLE TROLLEY

(LARGER CAPACITY)

Finish: Chassis & Cable Support – Steel, Zinc Plated with Passivation  
Clamp Mounting – Grey Nylon  
Wheels & Fasteners – Bright Zinc Plated

Weight: 0.500kg

Part No: 100/237



## TOWING TROLLEY

(LARGER CAPACITY)

Finish: Chassis/Cable Support/Tow Loop – Steel, Zinc Plated with Passivation  
Wheels & Fasteners – Bright Zinc Plated

Weight: 0.600kg

Part No: 100/237M

Wheels: Standard – Dust proof.  
Optional: Waterproof Wheels – add /SS to Part Number.



## SUSPENSION TROLLEY

Finish: Chassis – Zinc Plated with Passivation  
Bright Zinc Plated – Dustproof Wheels  
Optional 'V' bolt assembly

Weight: 0.155kg

Part No: 100/137ST

Add /VL to part number if 'V' bolt required, add /TL to part number if 'U' bolt also required.

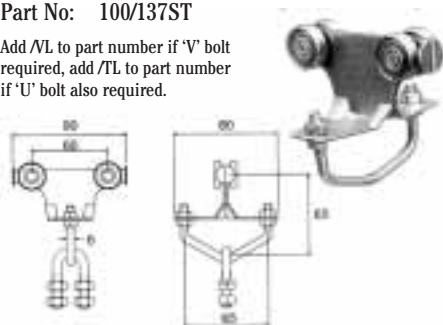

## SUSPENSION TROLLEY

Finish: Chassis – Zinc Plated with Passivation  
Bright Zinc Plated – Dustproof Wheels  
Optional 'U' bolt assembly

Weight: 0.175kg

Part No: 100/237ST

Add /TL to part number if 'U' bolt also required.

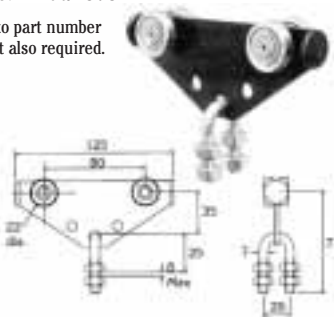

## JOIST CLIP SET

Finish: Galvanised Steel  
Weight: Flange Thickness – T: 0.150kg  
Mounting Height – h: 0.150kg

Clamping Screw: M8 x 50

Part No: JC850

(Comprising Clip, Bolt, Washer & Square Nut)

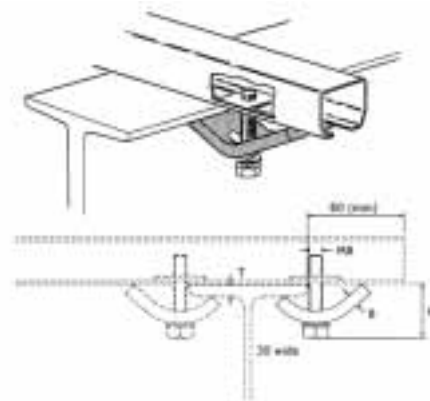

## ROUND CABLE SADDLE

(FOR USE WITH 100/137 TROLLEY)

Part No: mm  
03.49439.01 10-16  
03.49439.02 16-26  
03.49439.03 26-38



## ADAPTOR – FOR ROUND SADDLE

(FOR USE WITH 100/137 TROLLEY)

Part No: ME17010205



## MOBILE PENDANT TERMINAL BOX

Part No: MPB 100/S

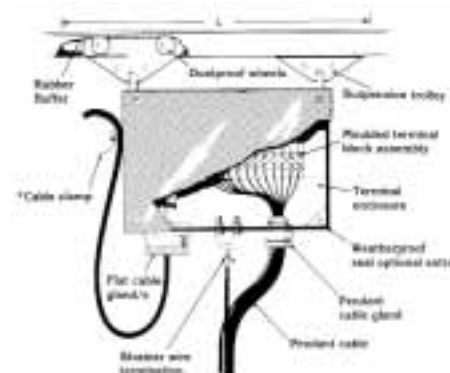

**MATERIAL:**

Body and plate support, injection molded plastic – 25mm rollers (ball bearings), galvanized steel.

**END CLAMP**

A: 55  
B: 75  
C: 80  
Code: 03.02132.90  
Weight kg: 0.815

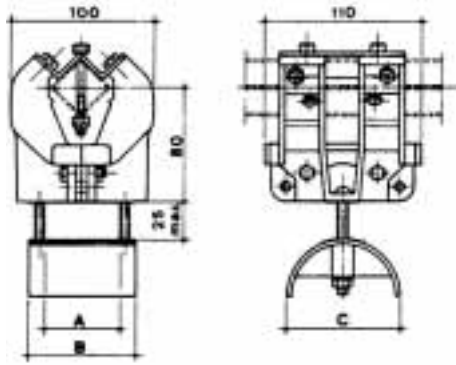

**INTERMEDIATE CARRIER**

A: 55  
B: 75  
C: 80  
Code: 03.02142.90  
Weight kg: 0.595

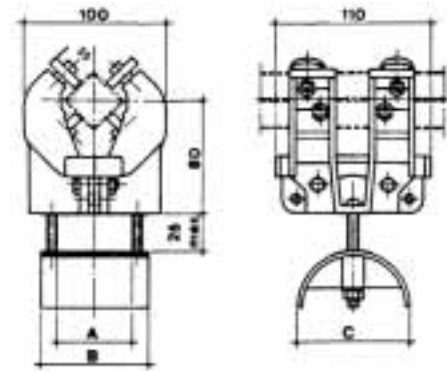

**LEADING CARRIER**

A: 55  
B: 75  
C: 80  
Code: 03.02152.90  
Weight kg: 0.840

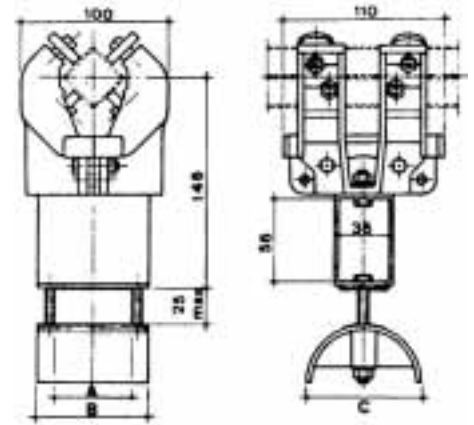

**DRILLING JIG & BUFFER STOP**

Code C3.BAT03.90  
Weight kg/m 0.700

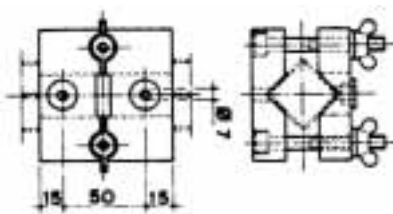

**SUSPENSION BRACKET**

Code 03.02001.90  
Weight kg/m 0.170

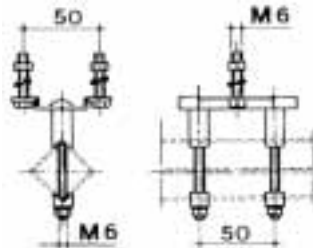

**JOINT**

Code 03.02002.90  
Weight kg/m 0.300

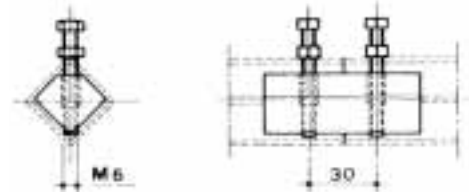

**MATERIAL:**

Aluminium – Steel

It serves to drill either the track rail at the extremities for mounting of the suspension brackets. When all drillings are executed the jig stalled at the extremity of line, works as buffer stop.

**MATERIAL:**

Galvanized – Steel

Stainless Steel optional.

**MATERIAL:**

Galvanized – Steel

## TRACK

Code	m.	Weight kg/m
03.02000.90	6	1.760

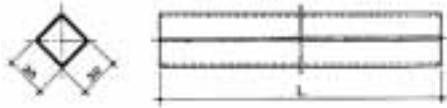

### MATERIAL:

Galvanised steel 30 x 30 x 2 square tube  
Stainless steel optional

## SHACKLE

Code	Weight kg/m
705000123	0.020

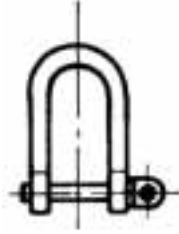

### MATERIAL:

Galvanized – Steel

## TENSION CHAIN

Code	Weight kg/m
705000106	0.095



### MATERIAL:

Galvanized – Steel

# Square 25 Festoon System

30 x 30 Square Track

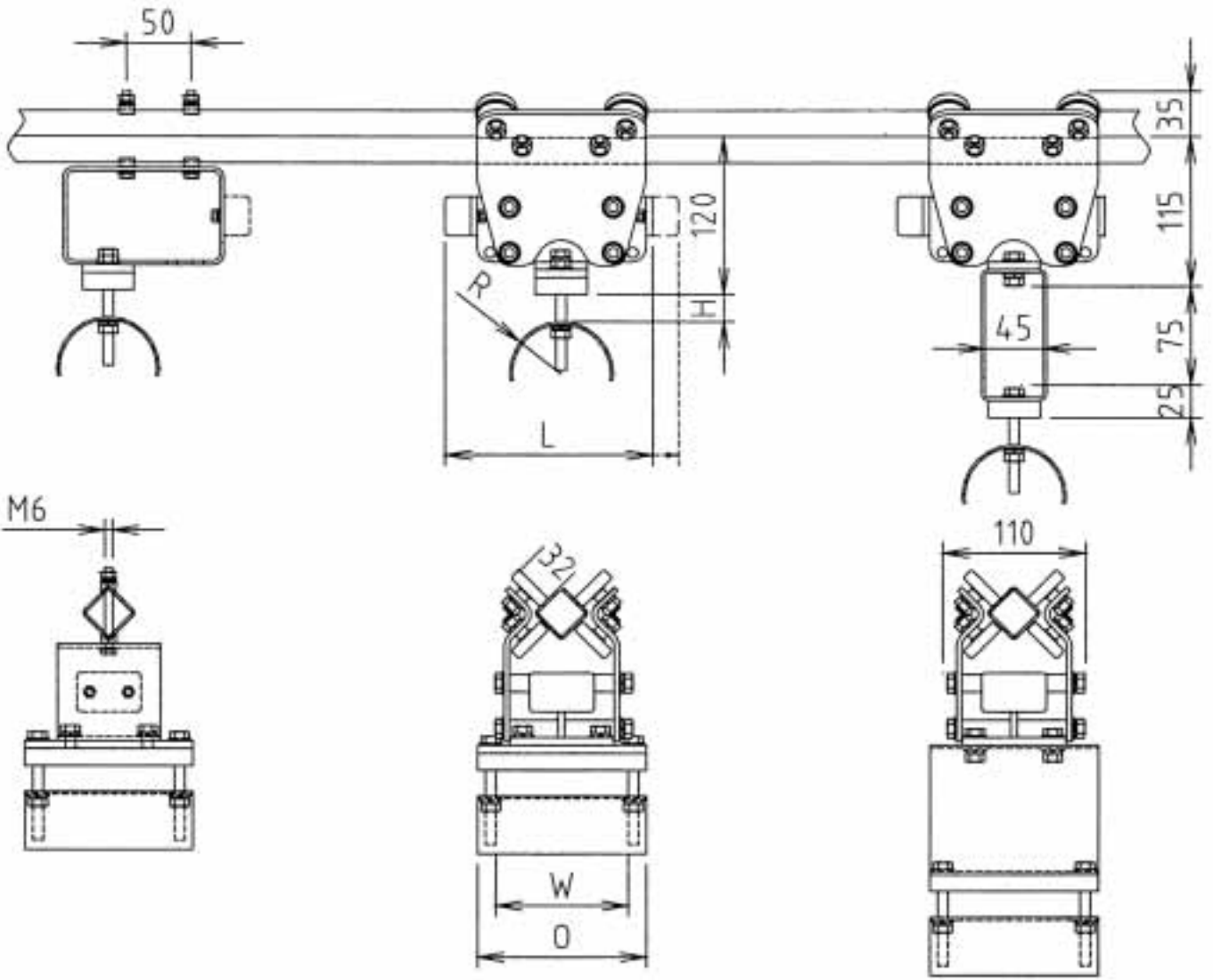

**END STOP AND CLAMP**

**INTERMEDIATE TROLLEY**

**LEAD TROLLEY**

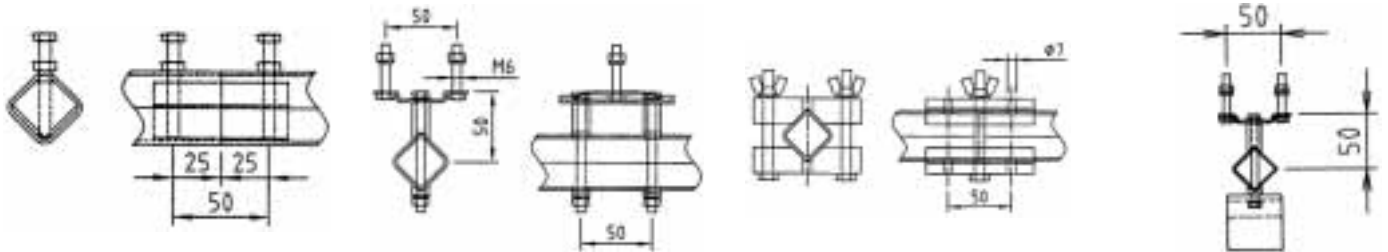

**SPLICE JOINT**

Part Number 03.02002.90

**SUSPENSION BRACKET**

Part Number 03.02001.90

**DRILL JIG**

Part Number C3.BAT03.90

**END STOP**

Part Number 25.1111.04

## TRACK

Code 03.02000.90  
m. 6  
Weight kg/m 1.760

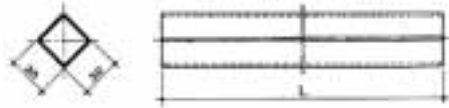

## SHACKLE

Code 705000123  
Weight kg/m 0.020

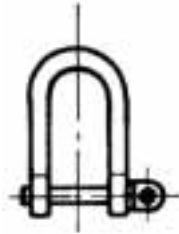

## TENSION CHAIN

Code 705000106  
Weight kg/m 0.095



## MATERIAL:

Galvanized steel 30 x 30 x 2 square tube  
Stainless steel optional

## MATERIAL:

Galvanized – Steel

## MATERIAL:

Galvanized – Steel

PART NUMBERS			DIMENSIONS			
Lead Trolley	Intermediate Trolley	End Clamp and Stop	Saddle Radius (R)	Cable Space (W x H)	Trolley Length (L)	Overall Width (O)
25.1111.01	25.1111.02	25.1111.03	40	50 x 35	160	80
25.1112.01	25.1112.02	25.1112.03	40	100 x 35	160	130
25.1113.01	25.1113.02	25.1113.03	40	150 x 35	160	180
25.1121.01	25.1121.02	25.1121.03	60	50 x 15	160	80
25.1122.01	25.1122.02	25.1122.03	60	100 x 15	160	130
25.1123.01	25.1123.02	25.1123.03	60	150 x 15	160	180
25.1211.01	25.1211.02	25.1211.03	40	50 x 45	180	80
25.1212.01	25.1212.02	25.1212.03	40	100 x 45	180	130
25.1213.01	25.1213.02	25.1213.03	40	150 x 45	180	180
25.1221.01	25.1221.02	25.1221.03	60	50 x 25	180	80
25.1222.01	25.1222.02	25.1222.03	60	100 x 25	180	130
25.1223.01	25.1223.02	25.1223.03	60	150 x 25	180	180
25.1321.01	25.1321.02	25.1321.03	60	50 x 35	200	80
25.1322.01	25.1322.02	25.1322.03	60	100 x 35	200	130
25.1323.01	25.1323.02	25.1323.03	60	150 x 35	200	180
25.1331.01	25.1331.02	25.1331.03	80	50 x 15	200	80
25.1332.01	25.1332.02	25.1332.03	80	100 x 15	200	130
25.1333.01	25.1333.02	25.1333.03	80	150 x 15	200	180
25.1421.01	25.1421.02	25.1421.03	60	50 x 45	220	80
25.1422.01	25.1422.02	25.1422.03	60	100 x 45	220	130
25.1423.01	25.1423.02	25.1423.03	60	150 x 45	220	180
25.1431.01	25.1431.02	25.1431.03	80	50 x 25	220	80
25.1432.01	25.1432.02	25.1432.03	80	100 x 25	220	130
25.1433.01	25.1433.02	25.1433.03	80	150 x 25	220	180
25.2555.01	25.2555.02	25.2555.03	Please Specify Track Size (T), Trolley Length (L), Saddle Radius (R) and Cable Space (W x H).			
Maximum Load – Maximum Speed –	25kg/trolley 60m/min		Standard Material and Finish – Standard Fasteners – Alternative materials, finishes and fasteners are available on request	Mild Steel, Hot Dip Galvanised Commercial Grade 4.6, Bright Zinc Plated		

# Square 50 Festoon System

## 40 x 40 Square Track

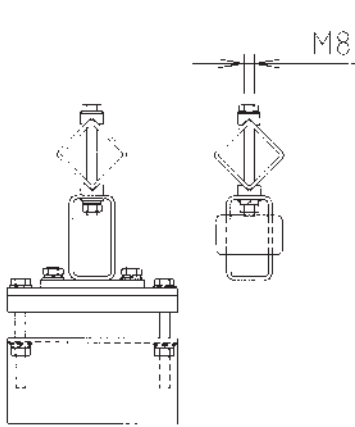
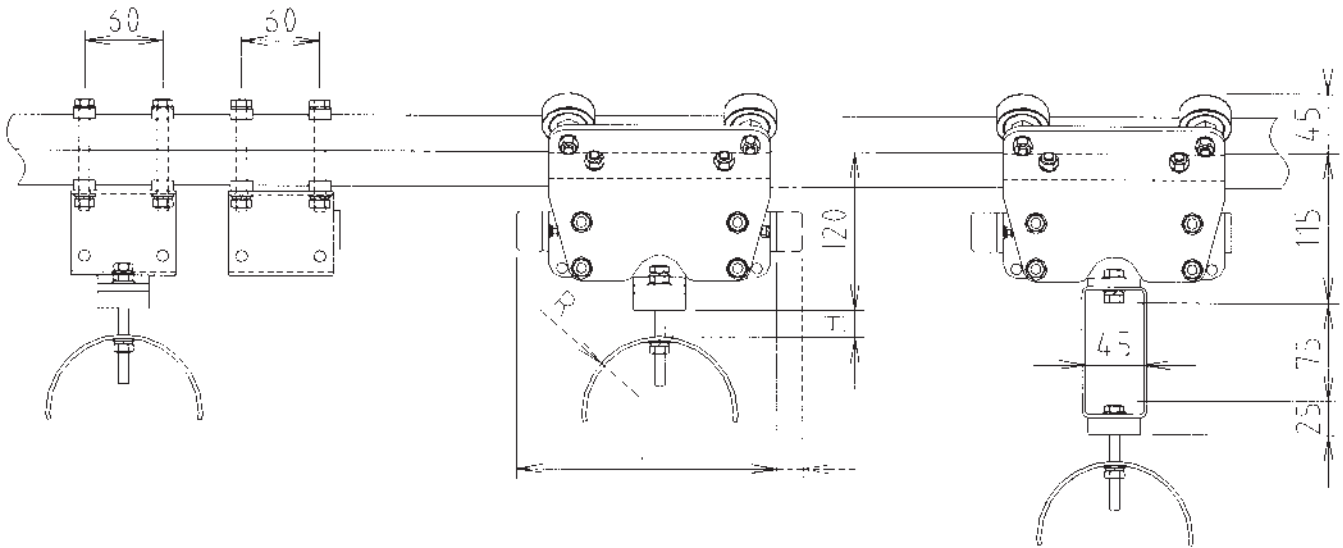

**END CLAMP AND END STOP**

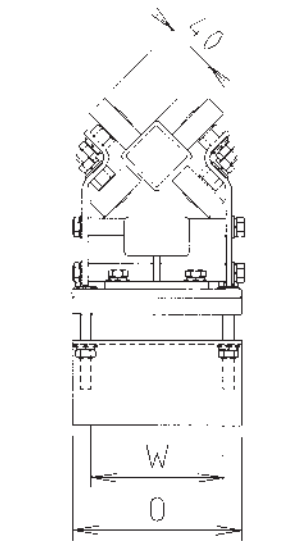

**INTERMEDIATE TROLLEY**

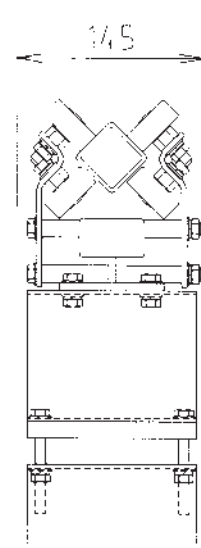

**LEAD TROLLEY**

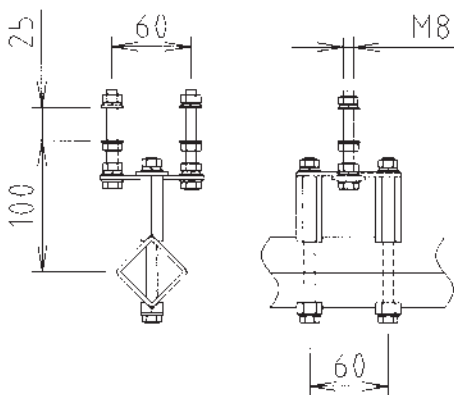

**SUSPENSION BRACKET**

Part Number 50.1111.51

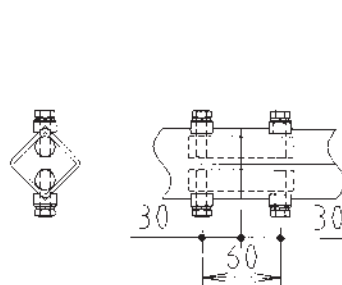

**SPLICE JOINT**

Part Number 50.1111.52

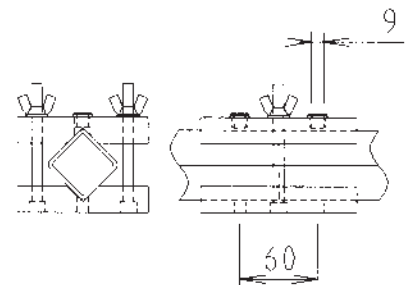

**DRILL JIG**

Part Number 50.1111.53

## TRACK

<b>Code</b>	<b>m.</b>	<b>Weight kg/m</b>
03.02000.93	8	3.30

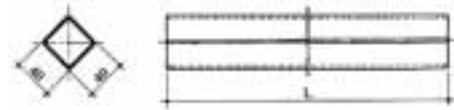

## SHACKLE

<b>Code</b>	<b>Weight kg/m</b>
705000123	0.020

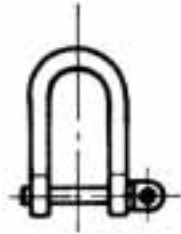

## TENSION CHAIN

<b>Code</b>	<b>Weight kg/m</b>
705000106	0.095



## MATERIAL:

Galvanised steel 40 x 40 x 3 square tube  
Stainless steel optional

## MATERIAL:

Galvanized – Steel

## MATERIAL:

Galvanized – Steel

PART NUMBERS			DIMENSIONS			
Lead Trolley	Intermediate Trolley	End Clamp and Stop	Saddle Radius (R)	Cable Space (W x H)	Trolley Length (L)	Overall Width (O)
50.1111.01	50.1111.02	50.1111.03	60	50 x 35	200	80
50.1112.01	50.1112.02	50.1112.03	60	100 x 35	200	130
50.1113.01	50.1113.02	50.1113.03	60	150 x 35	200	180
50.1121.01	50.1121.02	50.1121.03	80	50 x 15	200	80
50.1122.01	50.1122.02	50.1122.03	80	100 x 15	200	130
50.1123.01	50.1123.02	50.1123.03	80	150 x 15	200	180
50.1211.01	50.1211.02	50.1211.03	60	50 x 45	220	80
50.1212.01	50.1212.02	50.1212.03	60	100 x 45	220	130
50.1213.01	50.1213.02	50.1213.03	60	150 x 45	220	180
50.1221.01	50.1221.02	50.1221.03	80	50 x 25	220	80
50.1222.01	50.1222.02	50.1222.03	80	100 x 25	220	130
50.1223.01	50.1223.02	50.1223.03	80	150 x 25	220	180
50.1321.01	50.1321.02	50.1321.03	80	50 x 40	250	80
50.1322.01	50.1322.02	50.1322.03	80	100 x 40	250	130
50.1323.01	50.1323.02	50.1323.03	80	150 x 40	250	180
50.1331.01	50.1331.02	50.1331.03	100	50 x 20	250	80
50.1332.01	50.1332.02	50.1332.03	100	100 x 20	250	130
50.1333.01	50.1333.02	50.1333.03	100	150 x 20	250	180
50.1421.01	50.1421.02	50.1421.03	80	50 x 50	270	80
50.1422.01	50.1422.02	50.1422.03	80	100 x 50	270	130
50.1423.01	50.1423.02	50.1423.03	80	150 x 50	270	180
50.1431.01	50.1431.02	50.1431.03	100	50 x 30	270	80
50.1432.01	50.1432.02	50.1432.03	100	100 x 30	270	130
50.1433.01	50.1433.02	50.1433.03	100	150 x 30	270	180
50.2555.01	50.2555.02	50.2555.03	Please Specify Track Size (T), Trolley Length (L), Saddle Radius (R) and Cable Space (W x H).			
Maximum Load –	50kg/trolley		Standard Material and Finish –	Mild Steel, Hot Dip Galvanised		
Maximum Speed –	60m/min		Standard Fasteners –	Commercial Grade 4.6, Bright Zinc Plated		
			Alternative materials, finishes and fasteners are available on request			

Type	Measurement						Load Capacity		
	D mm	H mm	G mm	l mm	r mm	s2 mm	f mm	F kN	W J
040 x 032	40	32	M8	23	8	2	18	15	70
050 x 040	50	40	M10	28	10	2	22	24	140
063 x 050	63	50	M10	28	12.5	3	28	37.5	280
080 x 063	80	63	M12	37	18	3	35	60	560
100 x 080	100	80	M12	36	20	4	44	95	1120
125 x 100	125	100	M16	36	25	4	55	150	2240
160 x 125	160	125	M16	44	32	6	68	240	4400
200 x 160	200	160	M20	44	40	6	38	375	8800

Buffer Type	Maximum Load Capacity "F" (kN)	Deflection "f" at Maximum Load rating (mm)	Energy Capacity "W" at Maximum Deflection (J)
040 x 032	15	18	70
050 x 040	24	22	140
063 x 050	37.5	28	280
080 x 063	60	35	560
100 x 080	95	44	1120
125 x 100	150	55	2240
160 x 125	240	68	4400
200 x 160	375	88	8800

## GP-IG

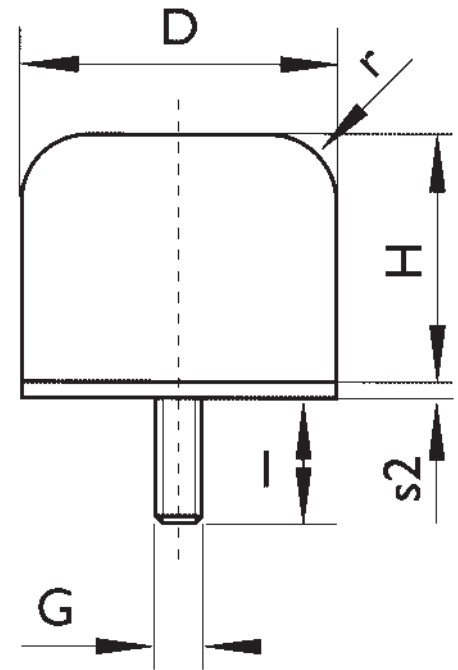

Buffers have the capacity to absorb a certain amount of energy (measured in Joules (J), value (W) in table above). In doing so, they deflect a certain distance (up to a maximum value of "f" as shown in the table above), and exert a gradually increasing reaction force (up to a maximum value of "F" as shown in table above).

When an object having mass "m" kilograms (kg) is travelling at velocity "v" metres per second (m/s), it has a value of kinetic energy (in Joules) equal to half the mass times the velocity squared:

$$\text{Kinetic Energy KE} = \frac{1}{2}mv^2$$

Note that when calculating the kinetic energy, the mass must be in kg and the velocity must be in m/s. To convert m/min to m/s, divide by 60.

## GP-QP

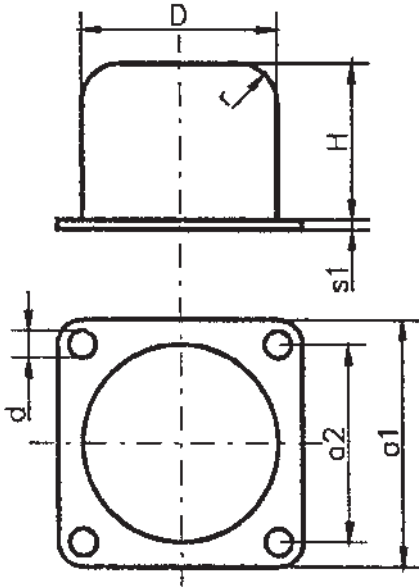

Type	Measurement		
	a1 mm	a2 mm	d mm
040 x 032	50	40	5.5
050 x 040	63	50	6.5
063 x 050	80	63	6.5
080 x 063	100	80	9
100 x 080	125	100	9
125 x 100	160	125	11
160 x 125	200	160	11
200 x 160	250	200	13

# Beam 65 Festoon System

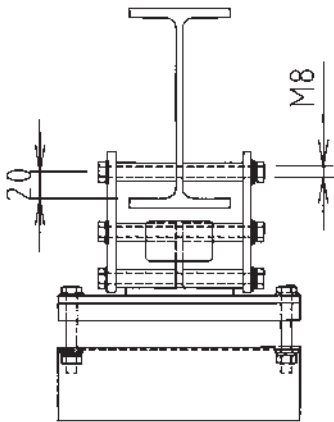
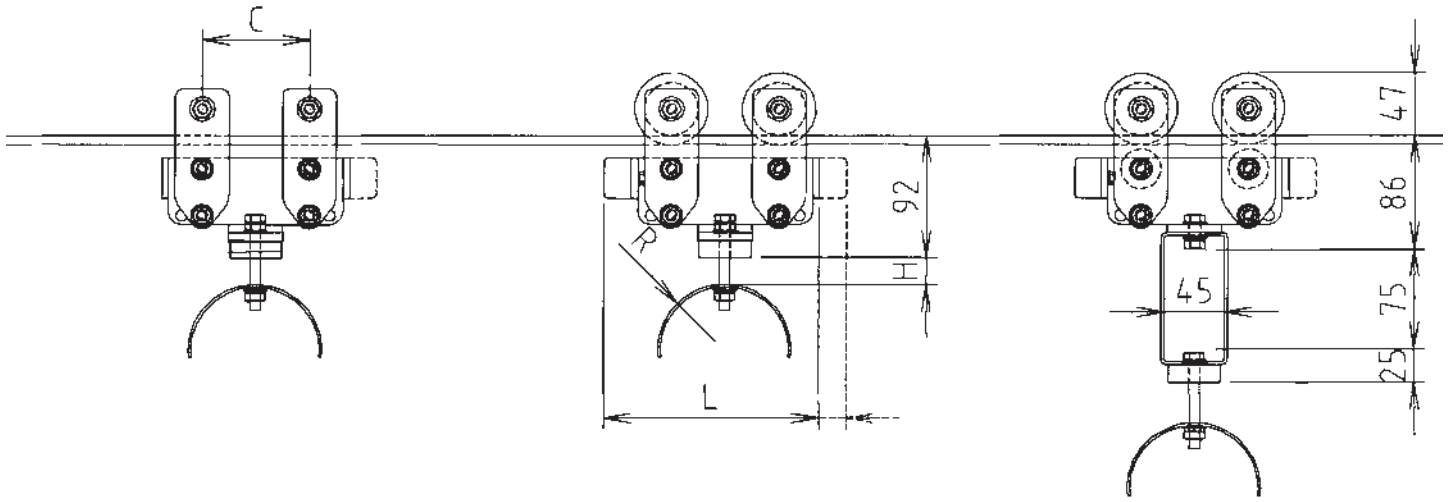

**END CLAMP**

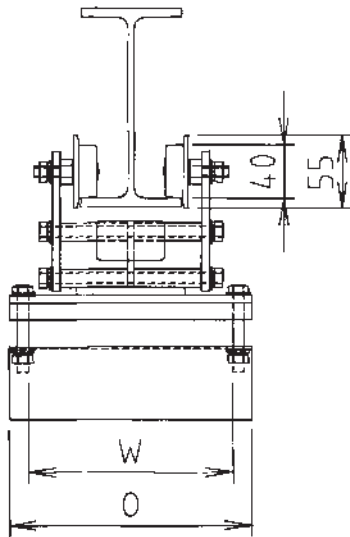

**INTERMEDIATE TROLLEY**

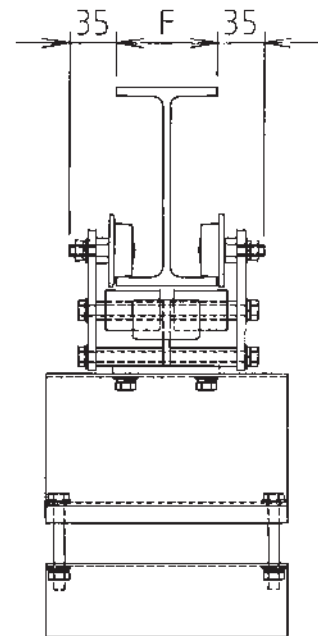

**LEAD TROLLEY**

PART NUMBERS			DIMENSIONS						
Lead Trolley	Intermediate Trolley	End Clamp and Stop	Saddle Radius (R)	Cable Space (W x H)	Trolley Length (L)	Overall Width (O)	Bolt Centres (C)		
65.1111.01	65.1111.02	65.1111.03	40	50 x 35	160	80	80		
65.1112.01	65.1112.02	65.1112.03	40	100 x 35	160	130	80		
65.1113.01	65.1113.02	65.1113.03	40	150 x 35	160	180	80		
65.1121.01	65.1121.02	65.1121.03	60	50 x 15	160	80	80		
65.1122.01	65.1122.02	65.1122.03	60	100 x 15	160	130	80		
65.1123.01	65.1123.02	65.1123.03	60	150 x 15	160	180	80		
65.1211.01	65.1211.02	65.1211.03	40	50 x 45	180	80	80		
65.1212.01	65.1212.02	65.1212.03	40	100 x 45	180	130	80		
65.1213.01	65.1213.02	65.1213.03	40	150 x 45	180	180	80		
65.1221.01	65.1221.02	65.1221.03	60	50 x 25	180	80	80		
65.1222.01	65.1222.02	65.1222.03	60	100 x 25	180	130	80		
65.1223.01	65.1223.02	65.1223.03	60	150 x 25	180	180	80		
65.1321.01	65.1321.02	65.1321.03	60	50 x 35	200	80	120		
65.1322.01	65.1322.02	65.1322.03	60	100 x 35	200	130	120		
65.1323.01	65.1323.02	65.1323.03	60	150 x 35	200	180	120		
65.1331.01	65.1331.02	65.1331.03	80	50 x 15	200	80	120		
65.1332.01	65.1332.02	65.1332.03	80	100 x 15	200	130	120		
65.1333.01	65.1333.02	65.1333.03	80	150 x 15	200	180	120		
65.1421.01	65.1421.02	65.1421.03	60	50 x 45	220	80	120		
65.1422.01	65.1422.02	65.1422.03	60	100 x 45	220	130	120		
65.1423.01	65.1423.02	65.1423.03	60	150 x 45	220	180	120		
65.1431.01	65.1431.02	65.1431.03	80	50 x 25	220	80	120		
65.1432.01	65.1432.02	65.1432.03	80	100 x 25	220	130	120		
65.1433.01	65.1433.02	65.1433.03	80	150 x 25	220	180	120		
65.1555.01	65.1555.02	65.1555.03	Please Specify Track Size (T), Trolley Length (L), Saddle Radius (R) and Cable Space (W x H).						
<i>Always Specify Beam Flange Width (F)</i>		Maximum Load – 65kg/trolley Maximum Speed – 60m/min	Standard Material and Finish – Mild Steel, Hot Dip Galvanised Standard Fasteners – Commercial Grade 4.6, Bright Zinc Plated Alternative materials, finishes and fasteners are available on request						

# Cavotec Metool

*Cavotec Metool has been designing and supplying cable and hose handling systems for Australian mining, port, steel and manufacturing industries for over three decades. Being Australian based gives Cavotec Metool a strong understanding of the unique requirements of Australian conditions. As specialists in electrical power feed systems, Cavotec Metool can provide excellent service to port and harbour operations, as well as electrical and mechanical businesses nationwide. With the resources of the Cavotec Group of companies behind it, Cavotec Metool is acknowledged as being a strong and viable partner to industry.*

## Cavotec Group Product Range

### The Cavotec Group

Cavotec is the name of a group of companies specialising in power supply technology for cranes and other industrial equipment. the group has 6 manufacturing companies located in Australia, France, Germany, Italy, Sweden and U.S.A., as well as 18 Cavotec sales companies which, together with a network of distributors, serve more than 30 countries on five continents. Each manufacturing company, no matter where it is located, aims at being a market leader in its field by providing innovative and reliable products to Group customers. Although they manufacture different products in different countries, they are globally supported and coordinated by the Cavotec Group in their product development and marketing activities. Each sales company, and each distributor, has a policy aiming at better serving its local market with the full support of the Cavotec Group.

### Our aim is to be local everywhere

Great emphasis is placed in providing the highest quality, not only in the selected products, but also in service and backing to our customers. Our philosophy in fact is to be local everywhere.

### The fields of application of our products are:



**Ports,  
Terminals**



**Mining,  
tunnelling**



**Steel Mills**



**Forestry**



**Robots,  
Automation**



**Offshore  
Marine**



**Constructions**

**Cavotec Metool Pty Ltd  
Offices**

**Newcastle Office**

28 Mitchell Road  
Cardiff NSW 2285  
phone: int. +61 (02) 4956 5788  
fax: int. +61 (02) 4956 5823

**Melbourne Office**

2/483 Hammond Road  
Dandenong VIC 3175  
phone: int. +61 (03) 9706 6788  
fax: int. +61 (03) 9706 6789

**Perth Office**

82 Chisholm Crescent  
Kewdale WA 6105  
phone: int. +61 (08) 9453 3952  
fax: int. +61 (08) 9453 3972

**Brisbane Office**

30 Norbury Street  
Coopers Plains QLD 4108  
phone: int. +61 (07) 3277 6050  
fax: int. +61 (07) 3255 6671

e-mail:

**sales@cavotecmetool.com.au**

web:

**www.cavotecmetool.com.au**

**Cavotec Group  
Sales Companies**

Argentina	Italy
Australia	Japan
Bahrain	Korea
BeNeLux	Kuwait
Brazil	Norway
Canada	Philippines
Chile	Saudi Arabia
China	Singapore
Denmark	South Africa
Egypt	Sweden
Finland	Taiwan
France	U.A.E.
Germany	U.K. & Ireland
Hong Kong	U.S.A.
Indonesia	

## CLT - spring driven cable reels



Manufactured by **Cavotec Alfo**

# CLT - spring driven cable reels

## Who we are

Cavotec is a multi-national group of companies serving the following industries: mining and tunnelling, ports and maritime, steel and aluminium, energy and offshore, airports, general industry and automation. In the early 1960's our main focus was the design and production of motorised cable reels primarily for manufacturers of tower cranes, harbour cranes and mining equipment. Today, Cavotec is connecting mobile equipment around the world in many diverse applications.

## Where we are

The Cavotec Group consists of 7 manufacturing "Centres of Excellence" located in Canada, France, Germany, Italy, Norway and Sweden and by 5 local manufacturing units located in Australia, China, Germany and the USA. For the distribution of products and providing support to customers Cavotec has 27 sales companies which, together with a network of distributors, serve more than 30 countries in five continents. The ultimate objective is to be perceived as "local everywhere".

## How we work

Our aim is to work closely with our customers in order to build long-term partnerships. To achieve this aim we have created a working environment that attracts the best people, encourages them to stay and brings out their best qualities. By producing totally reliable systems and backing them with efficient service, we strive to create true customer satisfaction.



## Cavotec Alfo

Established in 1991, Cavotec Alfo is a modern German manufacturing company in the specialised field of spring reels and slinging columns. In 1997 Cavotec Alfo became a member of the Cavotec Group, a world leader in cable reel technology, as one of its manufacturing units.

The Cavotec Alfo CLT spring reels are built from modular components which allow a great number of combinations covering most common requirements. The spring reels are strong and well designed in order to guarantee the highest reliability even in difficult applications. All reels are equipped with two, totally sealed bearings which are lubricated for life. Cavotec Alfo has been the first manufacturer to build its slings in a totally sealed and modular unit, fully separated from the mechanical parts. Protection of slings and reel is IP65/66.

Cavotec Alfo spring driven cable reels meet all applicable IEC international norms and standards and follow the latest EU-requirements (CE-marking).

# Cavotec Group Organization

As shown here the Cavotec Group is organised to support its customers around the world through its manufacturing units and sales companies.

Each Cavotec manufacturing company, no matter where it is located, aims at being a market leader in its field by providing innovative and reliable products to Group customers.

Each Cavotec sales company, in the 27 countries where they operate, aims at better serving its local market following the Group philosophy "to be local everywhere".

## Manufacturing network

### Centres of Excellence

#### France

##### Cavotec RMS

Spring Driven Reels

#### Germany

##### Cavotec Alfo

Spring Driven Reels

Slipring Columns

##### Cavotec Fladung

Aircraft Support Systems

Security Systems

#### Italy

##### Cavotec Specimas

Motorized Cable Reels

Panzerbelt Cable Protection

Slipring Columns

#### Norway

##### Cavotec Micro-control

Radio Remote Controls

#### Sweden

##### Cavotec Connectors

Electrical Plugs & Sockets

#### New Zealand

##### Cavotec MoorMaster

Automated Mooring Systems

### Local Manufacturing

#### Australia

##### Cavotec Australia

Motorized Cable Reels

#### China

##### Cavotec China

Product Assembly

#### Germany

##### Cavotec Micro-control

Radio Remote Controls

#### Sweden

##### Cavotec Sweden

Product Assembly

#### USA

##### Cavotec USA

Product Assembly

### Group Partners

#### Belgium

##### Gantry

Crane Rail Systems

#### Italy

##### Brevetti Stendalto

Cable Chains

##### Prysmian (Pirelli)

Flexible Cables

##### Tratos Cavi

Flexible Cables

## Sales network

### Cavotec Sales Companies

Cavotec Australia  
 Cavotec Belgium\*  
 Cavotec BeNeLux  
 Cavotec Brazil\*  
 Cavotec Canada  
 Cavotec Chile  
 Cavotec China  
 Cavotec Denmark  
 Cavotec Finland

Cavotec France  
 Cavotec Germany  
 Cavotec Hong Kong  
 Cavotec India  
 Cavotec Italy  
 Cavotec Korea  
 Cavotec Latin America  
 Cavotec Mexico  
 Cavotec Middle East

Cavotec Norway  
 Cavotec Russia\*  
 Cavotec Singapore  
 Cavotec South Africa  
 Cavotec Sweden  
 Cavotec Turkey  
 Cavotec UK & Ireland  
 Cavotec USA

\* Branch Office

# General Information

Spring driven cable reels are subject to the standards and norms as specified in the latest edition of VDE 0100 and the UVV.

The springs are made of special high-grade steel which guarantees a long lifetime. Every spring is mounted inside a spring housing in order to avoid friction and wear.

The slipping assembly is mounted in a solid glassfiber reinforced plastic housing that can withstand corrosion and mechanical wear. The housing is designed to minimise condensation and to guarantee complete water tightness through glands and seals.

Corrosion protection is also an important feature of Cavotec Alfo reels. All steel plates and parts are either hot dip galvanised or have a polyester coating. Cavotec Alfo offers, as an option, all external parts such as screws, nuts and bolts in stainless steel.

Our warranty follows the general delivery conditions of the electric industry for products and services. Wear parts are exempted from the warranty. See also our Terms of Delivery.

## Instructions regarding installation

The drum should be installed in such a way to ensure that the cable is reeled and unreeled to and from the drum without interference. Forced guidance and too small bending radius on sheaves and roller guides should be avoided at all times. The innovative design of the Cavotec Alfo spring reels allows the feeding point of the cable to be placed on either side of the drum. To relieve tension ensure that 1 or 2 additional reeling turns ( $d \cdot \pi \cdot 2$ ) remain on the drum when the maximum traveling distance has been reached.

For examples please refer to page 6.

## Cable selection

Our cable range includes a wide variety of flexible cables for reeling applications which can withstand the highest

mechanical stresses and harsh ambient conditions.

When selecting the cable, please take into consideration the cable data and the instructions provided by the manufacturer. In order to make the correct reel selection it is absolutely necessary to know the correct operating conditions. It is important to take into consideration the heating of the cable due to the number of layers on the drum and not to exceed the maximum allowed tension of the cable.

The data contained in the selection tables on page 7 are related to flexible cables of short lengths. The ambient temperature is assumed to be within  $+30^{\circ}\text{C}$  to  $-10^{\circ}\text{C}$ . Lower temperatures may require a higher spring force due to the higher rigidity of the cable.

The drum selection tables have been calculated with the maximum values (of each bracket) of diameter and weight. Consequently there could be significant deviations in specific cases.

## Reeling cable on drum

It is an absolute necessity to reel the cable onto the drum without twists or bends. To this end, lay out the complete cable straight along the travel length. When reeling the cable on the drum be sure to maintain the same reeling direction used on the wooden drum delivered by the manufacturer.

## Selecting the cable cross-section

When selecting the cable cross-section it is important to take in consideration the maximum current allowed (thermal heating) and the voltage drop limits, as well as the maximum tension allowed. The most important factors are:

1. Max. current load allowed according to norms and manufacturer's data.
2. Reduction factors due to duty cycle
3. Ambient temperature
4. Number of cable layers on the drum

**Important:** The number of layers  $L_z = 4$  should not be exceeded as  $L_z > 4$  gives higher current reduction and worse reeling conditions. You will find the upper limits in the selection tables.

5. Reduction factor when using multi-core cables. Relevant values are given by the cable manufacturer.

## Using roller guides and sheaves

When roller guides and sheaves are used, it is important to avoid reverse bending whenever possible. The following example illustrates the correct usage of roller guides.

## Unreeling direction

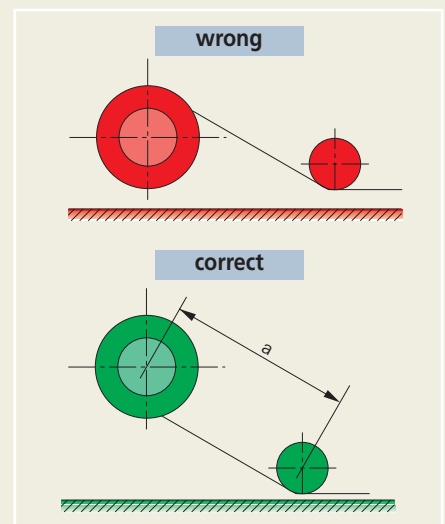

Standard unreeling direction is anticlockwise, when looking into the slipping body, i.e. to the left when unreeling the cable.

## Code key

22	36	12	20	BC	—	45	07
----	----	----	----	----	---	----	----

**22 - 36 Drum size**  
22: 220mm inner Ø  
36: 360mm outer Ø  
12: 125mm drum width

**45 - 07 Slipping assembly**  
45: Slipping type  
07: number of poles incl. PE (earth)

**20 BC Spring type**  
20: number and configuration of springs  
BC: type of spring

**Operating voltages**

Please find the operating voltages in the respective sliping data tables.

**Maximum current values**

All drums and sliping bodies are designed for the maximum allowed current values of the cable at 100% ED. (duty cycle). Please find the maximum allowed values in the respective sliping data tables.

**Earth conductor and number of poles**

All drums and sliping bodies for voltages > 24V are manufactured with an un-insulated protective earth conductor (PE). Number of poles = number of insulated poles including PE. In your order form, please state the number of poles, protective earth conductor, and operating voltage.

**Extreme operating conditions**

Extreme environmental and operating conditions must be given additional attention. The following factors are of primary importance:

- extreme high and low temperatures
- significant temperature variations
- high air humidity
- strong vibrations
- heavily polluted and aggressive air
- use in a marine environment

The force of the springs in spring reeling drums, may have to be increased if:

- the unit is moving at very low speed ( $v < 10$  m/min)
- significant deflections of the cable is necessary
- at high acceleration and speeds
- the temperature is lower than  $-10^{\circ}\text{C}$ .

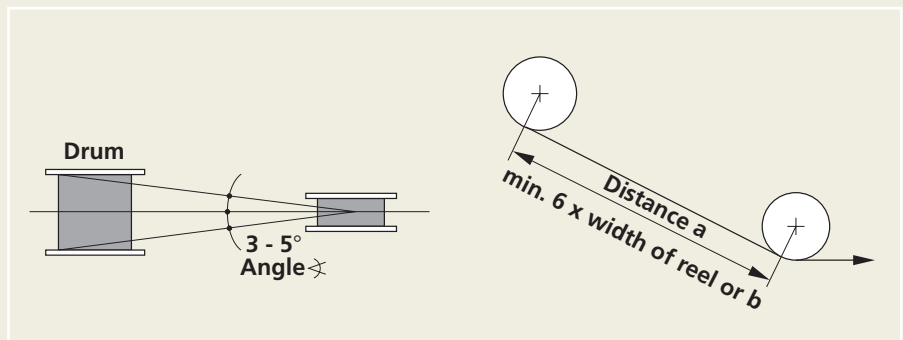
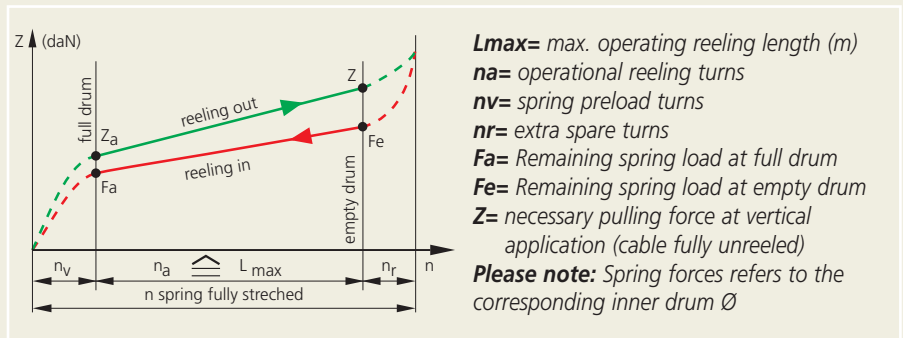

When spring reels are mounted low, the cable must always leave the drum from the top. If roller guides or sheaves are used it is important to respect a minimum distance (a) between drum and guide.



Cavotec Alfo spring driven reels are a common sight in theatre applications around the world.

# General Information

## APPLICATION EXAMPLES

### Case 1 & 2

#### Horizontal mobile application

The cable is unreeled on a flat and continuous surface. The cable is unreeled horizontally in either travelling directions.

### Case 3 & 4

#### Horizontal mobile application

The cable is reeled out on supports ( $L1 < 1\text{ m}$ ) or on rollers or rounded smooth supports ( $L1 = 1$  to  $3\text{ m}$ , depending on the cable size). The cable is unreeled horizontally in either travelling directions.

### Case 5

#### Stationary application

The cable is unreeled horizontally in either travelling directions through support rollers ( $L1 = 1$  to  $3\text{ m}$ , depending on the cable size). *This type of application is not recommended.*

### Case 6 & 7

#### Horizontal mobile application

The cable is unreeled horizontally, above the ground and without support, in either travelling directions. The catenary  $f1$  must be calculated accurately. As a rule the value of  $f_{\text{max}}$  is approximately 10% of  $L$ .

### Case 8 & 9

#### Vertical application

The cable is unreeled vertically downwards (downward inclination). Alternatively the cable is unreeled vertically upwards (upward inclination).

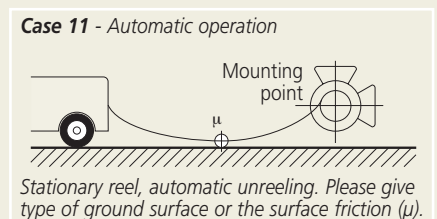
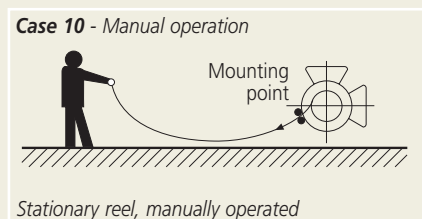
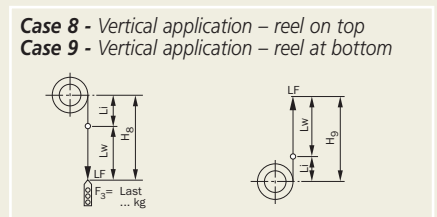
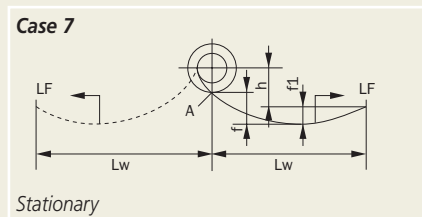
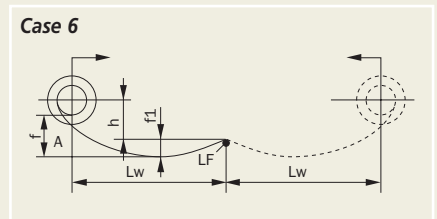
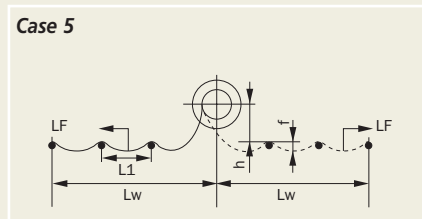
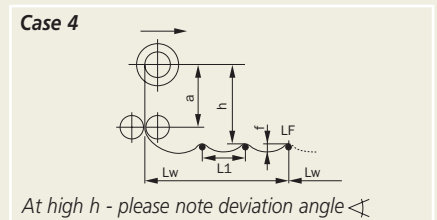
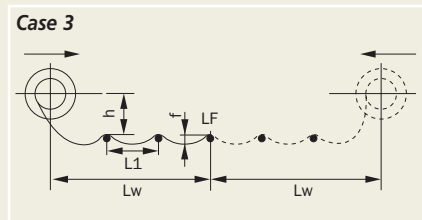
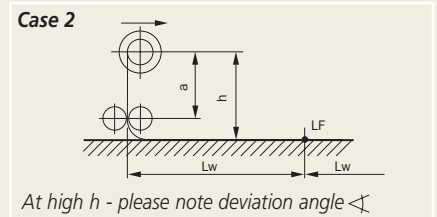
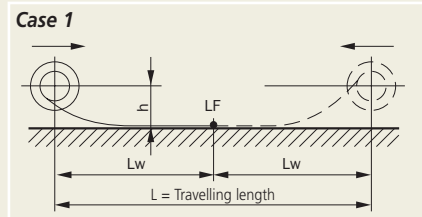

Explanation of the symbols (case 1 to 7): **Lw**= maximum reeling cable length [m], (reeling length for reels travelling in both directions = one-half of the total travelling length); **h**= (installation height) distance between cable deposit plane and drum centre [m]; **LF**= cable feeding point; **f**= maximum cable sag [m], in case 6 and 7 related to position A in drawing; **f1**= maximum cable sag [m], related to cable feeding point LF; **L1**= roller or support distance [m]

$$\text{Calculation formula } f1 (m) \sim \frac{10 \times L^2 \times g}{8 \times F}$$

**L**= support distance [m]; **g**= cable weight [kg/m]; **F**= pulling force [Newton]

Explanation of the symbols (case 8 and 9): **Lw**= maximum reeling cable length [m]; **H8/9**= maximum cable length hanging down from the drum [m]. The drum is selected according to the total cable weight of the hanging cable. Additional weight (F3) must be considered and added to the cable weight.



# General Information

## CABLE CALCULATION TABLES

Selecting the correct cable for your application is extremely important. This page shows the Cavotec Alfo range of cables and their relative technical specifications. For specific help in selecting the correct cable or, if you have any special requirement for your type of application, please contact your local Cavotec office.

### Special reeling cables - NSHT

Cross sec.	kg/km	Ø (mm)	Max. allowed tension
			N
4 x 1,5	157	10,2	150
5 x 1,5	176	10,8	190
7 x 1,5	245	12,9	265
12 x 1,5	337	16,8	450
18 x 1,5	526	18,6	675
24 x 1,5	662	21,3	900
30 x 1,5	901	24,6	1125
36 x 1,5	934	25,4	1350
42 x 1,5	1056	26,5	1575
4 x 2,5	208	11,7	250
5 x 2,5	263	12,7	315
7 x 2,5	327	14,8	440
12 x 2,5	533	20	750
18 x 2,5	725	21,1	1125
24 x 2,5	988	24,8	1500
30 x 2,5	1242	27,6	1875
36 x 2,5	1325	28,2	2250
4 x 4	270	12,5	600
5 x 4	362	14,3	900
4 x 6	409	16,9	900
5 x 6	511	17,8	750
7 x 6	715	20,9	1050
4 x 10	633	19,6	1000
5 x 10	766	20,9	1250
4 x 16	936	23,8	1600
5 x 16	1173	25,5	2000
4 x 25	1483	27,7	2500

### Calculation table for multi-layer reels/drums (VDE 0298 part 4 1995 table 19)

No. of layers	1	2	3	4	5
Correction factor	0,76	0,58	0,47	0,4	0,38

Note: for spiraled cables the correction factor is 0,76.

### Current capacity correction factor for multi-core cables\*°

No. loaded conductors	5	7	10	14	19	24	40	61
Correction factor	0,75	0,65	0,55	0,50	0,45	0,40	0,35	0,30

\* VDE 0298 part 4 1995 table 18

° max. conductor size 10 mm<sup>2</sup>

### Ambient temperature for NSHT cable

Temperature °C	25-30	30-35	35-40	40-45	45-50	50-55	55-60	60-65	65-70	70-75
Correction factor	1	0,95	0,98	0,84	0,77	0,71	0,63	0,55	0,45	0,32

## CLT MODULAR SYSTEM

The concept of the Cavotec Alfo CLT reels is to provide a modular system that retains all the quality and reliability of a standard spring driven cable reel. To guarantee the above, all assembly will take place at Cavotec Alfo by our specially trained and experienced staff. Only when requested will we ship the separate components of the CLT reels unassembled. In this case the modular design allows for easy storage and thanks to the innovative design of the reels, replacing just one part is extremely easy.

The photographs on right show the different packages that can be ordered from Cavotec Alfo. Please refer to the code-tables on the following pages to ascertain the correct codes for your specific CLT reel.

Side plates



Mounting flange



Slipping collector



Spring body



Mounted drum



Drum mounted with cable



# Spring driven cable reel CLT 220

## CHOICE OF CABLE REEL ACCORDING TO SEARCH KEY 1.1 TO 4.6

Cable (*)		Reeling length Lw (m), Case 1		h ≤ 1m																																					
∅ (mm) from ... to ...	Weighth kg/m max.																																								
<8	0.09	1	2	3	4	5	6	7	8	9	10	11	12	13	14	15	16	17	18	19	20	21	22	23	24	25	26	27	28	29	30	31	32	33	34	35	36	37	38	39	40
8 - 10	0.15	1,1				2,2										3,6					4,5																				
10 - 12	0.25	2,3																																							
12 - 14	0.30																																								
14 - 16	0.40																																								
16 - 18	0.45	3,4																																							
18 - 20	0.55																																								
20 - 22	0.70																																								

Cable (*)		Reeling length Lw (m), Case 8		Lw = H																																					
∅ (mm) from ... to ...	Weighth kg/m max.																																								
<8	0.09	1	2	3	4	5	6	7	8	9	10	11	12	13	14	15	16	17	18	19	20	21	22	23	24	25	26	27	28	29	30	31	32	33	34	35	36	37	38	39	40
8 - 10	0.15	1,1				3,4																																			
10 - 12	0.25																																								
12 - 14	0.30																																								
14 - 16	0.40	2,4				3,5																																			
16 - 18	0.45																																								
18 - 20	0.55	2,6				4,6																																			
20 - 22	0.70																																								

Gray background: Diameter of axis hole is 15mm



The photograph shows a CLT 220 reel mounted with a SK 58 slipring collector.

Search key	Drum type
1.1	22300810BC –
2.2	22361220BC –
2.3	22431220DC –
2.4	22360810DC –
3.4	22431630DC –
4.5	22432040DC –
2.6	22431220DC –
3.5	22431630EB –
3.6	22431630DC –
4.6	22431220EB –

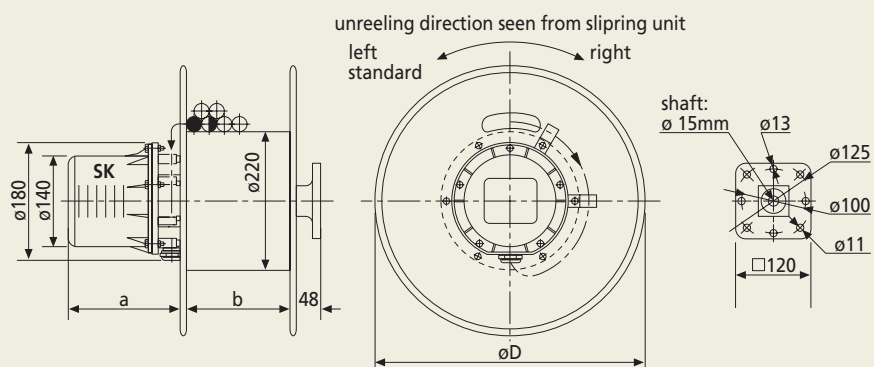

Spring-body	b	Turns (work)	n <sub>v</sub>	n <sub>r</sub>	Z (daN)	Fe (daN)	Item-Nr.
Spring-body 22..0810DC	85mm	13	2	1,5	10,8	10,3	A01-C10DC08-0
Spring-body 22..0810BC	85mm	16	3	1,5	6,1	6,1	A01-C10BC08-0
Spring-body 22..1212DC	125mm	13	2	1,5	21,6	20,6	A01-C12DC12-0
Spring-body 22..1220EB	125mm	18	5	2	15,0	14,5	A01-C20EB12-0
Spring-body 22..1220DC	125mm	26	4	3	10,8	10,3	A01-C20DC12-0
Spring-body 22..1220BC	125mm	32	8	3	6,1	6,1	A01-C20BC12-0
Spring-body 22..1630EB	165mm	27	7,5	3	15,0	14,5	A01-C30EB16-0
Spring-body 22..1630DC	165mm	39	6	4,5	10,8	10,3	A01-C30DC16-0
Spring-body 22..2024DC	205mm	52	8	6	10,8	10,3	A01-C40DC20-0

Other spring configurations upon request

Side plate (2 pcs.)	D	Item-Nr.
Side plate CLT 22-30	300mm	A04-C22-30-0Z
Side plate CLT 22-36	360mm	A04-C22-36-0Z
Side plate CLT 22-43	430mm	A04-C22-43-0Z

Slipping-body	No. rings	Max. cable types	Current	Max. Voltage	a	ø Housing	PG	Item-Nr.
GSK CLT 45-04	3 x 25A + PE	4 x 2,5	50mA - 25A	415V	130mm	140mm	16	A02-C450414-0
GSK CLT 45-05	4 x 25A + PE	5 x 2,5	50mA - 25A	415V	150mm	140mm	16	A02-C450514-0
GSK CLT 45-07	6 x 25A + PE	7 x 2,5	50mA - 25A	415V	190mm	140mm	16	A02-C450714-0
GSK CLT 45-12	11 x 25A + PE	12 x 2,5	50mA - 25A	415V	245mm	140mm	21	A02-C451214-0
GSK CLT 45-18	17 x 25A + PE	18 x 2,5	50mA - 25A	415V	325mm	140mm	21	A02-C451814-0
GSK CLT 46-04	3 x 25A + PE	4 x 4	50mA - 25A	415V	130mm	140mm	21	A02-C460414-0
GSK CLT 46-05	4 x 25A + PE	5 x 4	50mA - 25A	415V	150mm	140mm	21	A02-C460514-0
GSK CLT 47-04	3 x 50A + PE	4 x 6	50mA - 50A	500V	150mm	140mm	21	A02-C470414-0
GSK CLT 47-05	4 x 50A + PE	5 x 6	50mA - 50A	500V	160mm	140mm	21	A02-C470514-0
GSK CLT 58-04	3 x 16A + PE	4 x 1,5	30mA - 16A	500V	130mm	140mm	21	A02-C580414-5
GSK CLT 58-12	11 x 16A + PE	12 x 1,5	30mA - 16A	500V	130mm	140mm	21	A02-C581214-5

Deviating other types upon request

Mounting flange	Item-Nr.
Mounting flange	AA4-A00411-0A
Mounting flange with roll back lock	A09-D01922-0Z

Accessories	Item-Nr.
Extension of width b + 40 mm	AA4-G22821-0B
Rigid mounting base	AA9-L05361-0Z
Guidearm short b= 85	A06-A1955080Z
Guidearm short b=125	A06-A1955120Z
Guidearm short b=165	A06-A1955160Z

# Spring driven cable reel CLT 280

## CHOICE OF CABLE REEL ACCORDING TO SEARCH KEY 1.1 TO 7.4

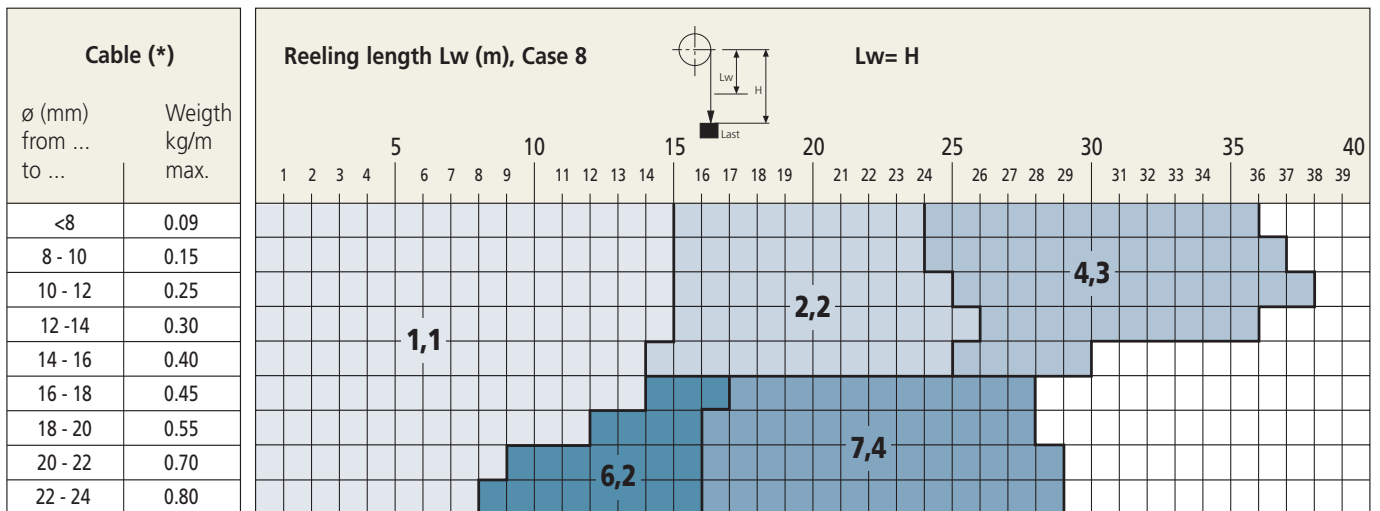
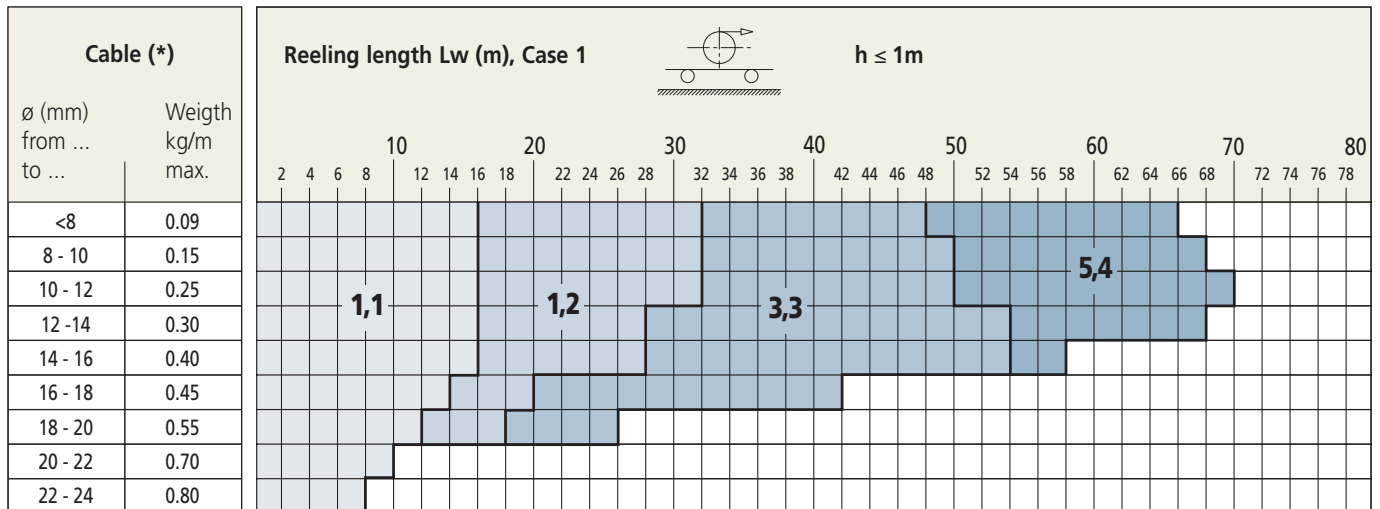

A SK 47 type slipping collector mounted inside its housing.

Search key	Drum type
1.1	28431610EA -
1.2	28431620EA -
2.2	28431610EA -
3.3	28432030EA -
4.3	28502030HA -
5.4	28502040EA -
6.2	28501612EA -
7.4	28502022HA -

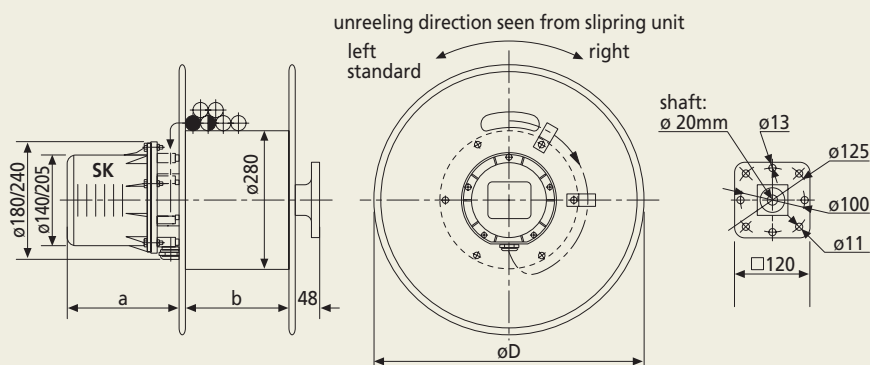

Spring-body	b	Turns (work)	$n_v$	$n_r$	Z (daN)	Fe (daN)	Item-Nr.
Spring-body 28..1610EA	165mm	17	3	1,5	12,0	10,0	A01-C10EA16-0
Spring-body 28..1620EA	165mm	34	6	3	12,0	10,0	A01-C20EA16-0
Spring-body 28..1620HA	165mm	26	6	3	19,0	17,5	A01-C20HA16-0
Spring-body 28..2030EA	205mm	51	9	4,5	12,0	10,0	A01-C30EA20-0
Spring-body 28..2030HA	205mm	39	9	4,5	19,0	17,5	A01-C30HA20-0
Spring-body 28..2040EA	205mm	68	12	6	12,0	10,0	A01-C40EA20-0
Spring-body 28..1612EA	165mm	17	3	1,5	24,0	20,0	A01-C12EA16-0
Spring-body 28..2022EA	205mm	26	6	3	38,0	35,0	A01-C22HA20-0

Other spring configurations upon request

Side plate (2 pcs.)	D	Item-Nr.
Side plate CLT 28-43	430mm	A04-C28-43-0Z
Side plate CLT 28-50	500mm	A04-C28-50-0Z

Spring-body	No. rings	Max. cable types	Current	Max. Volatge	a	$\phi$ Housing	PG	Item-Nr.
GSK CLT 45-04	3 x 25A + PE	4 x 2,5	50mA - 25A	415V	130mm	140mm	16	A02-C450414-0
GSK CLT 45-05	4 x 25A + PE	5 x 2,5	50mA - 25A	415V	150mm	140mm	16	A02-C450514-0
GSK CLT 45-07	6 x 25A + PE	7 x 2,5	50mA - 25A	415V	190mm	140mm	16	A02-C450714-0
GSK CLT 45-12	11 x 25A + PE	12 x 2,5	50mA - 25A	415V	245mm	140mm	21	A02-C451214-0
GSK CLT 45-18	17 x 25A + PE	18 x 2,5	50mA - 25A	415V	325mm	140mm	21	A02-C451814-0
GSK CLT 46-04	3 x 25A + PE	4 x 4	50mA - 25A	415V	130mm	140mm	21	A02-C460414-0
GSK CLT 46-05	4 x 25A + PE	5 x 4	50mA - 25A	415V	150mm	140mm	21	A02-C460514-0
GSK CLT 47-04	3 x 50A + PE	4 x 6	50mA - 50A	500V	150mm	140mm	21	A02-C470414-0
GSK CLT 47-05	4 x 50A + PE	5 x 6	50mA - 50A	500V	160mm	140mm	21	A02-C470514-0
GSK CLT 02-04	3 x 50A + PE	4 x 10	50mA - 50A	500V	205mm	205mm	29	A02-C 200420-0
GSK CLT 03-04	3 x 90A + PE	4 x 16	50mA - 90A	500V	205mm	205mm	29	A02-C030420-0
GSK CLT 98-24	23 x 25A + PE	24 x 2,5	30mA - 25A	500V	205mm	205mm	29	A02-C982420-0
GSK CLT 58-04	3 x 16A + PE	4 x 1,5	30mA - 16A	500V	130mm	140mm	21	A02-C580414-5
GSK CLT 58-12	11 x 16A + PE	12 x 1,5	30mA - 16A	500V	130mm	140mm	21	A02-C581214-5

Deviating other types upon request

Mounting flange	Item-Nr.
Mounting flange	AA4-A00412-0A
Mounting flange with roll back lock	A09-D02800-0Z

Accessories	Item-Nr.
Rigid mounting base	AA9-L05361-0Z
Guidearm short b= 165	A06-A1955160Z

# Spring driven cable reel CLT 400

## CHOICE OF CABLE REEL ACCORDING TO SEARCH KEY 1.1 TO 5.21

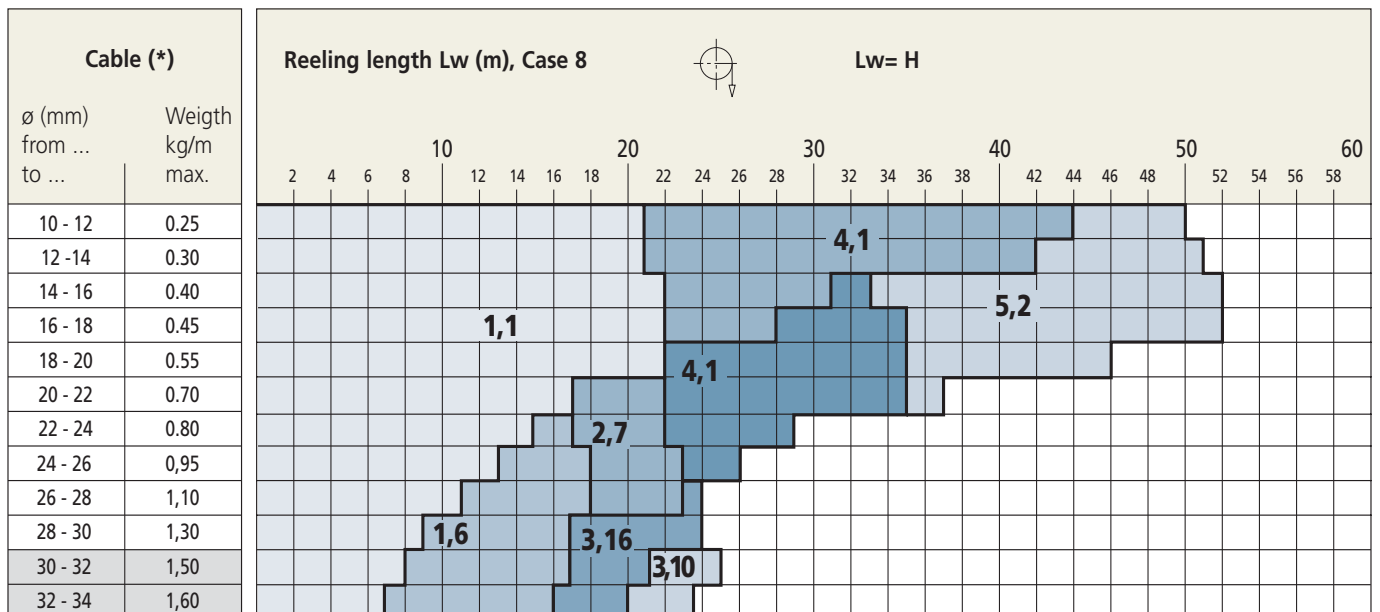
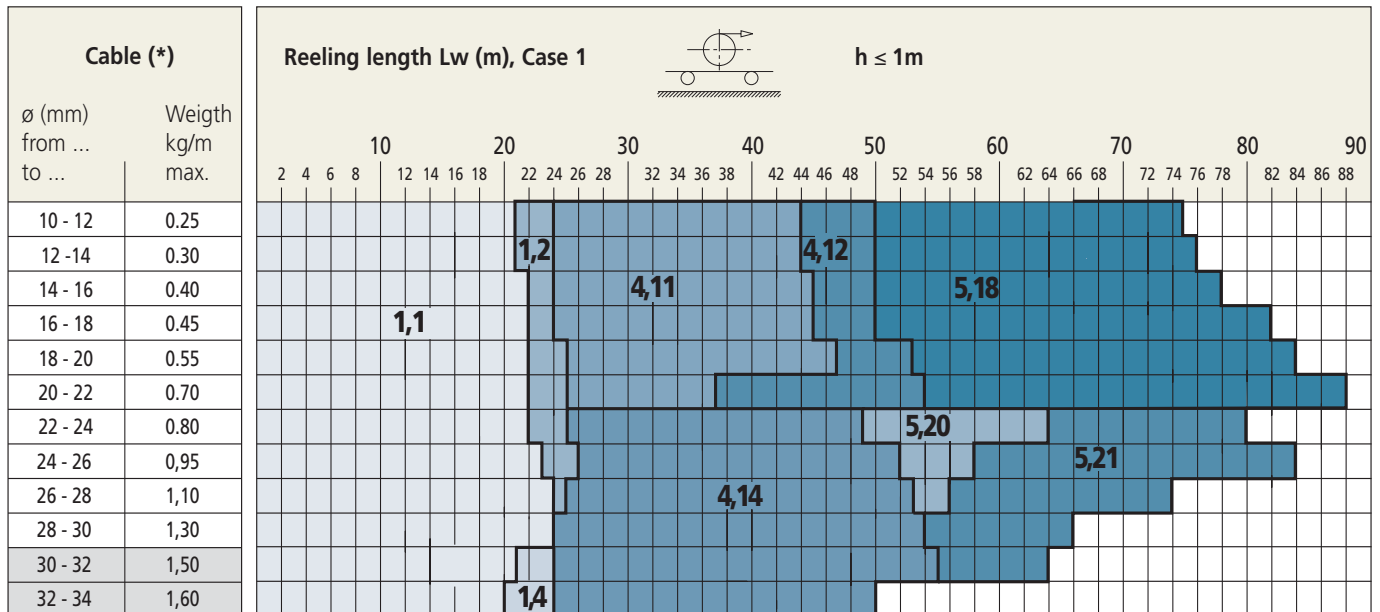

Gray background: Diameter of axis hole is 30mm

Search key	Drum type
1.1	40562810TA -
1.2	40562810SA -
1.4	40712810TA -
1.6	40632810UA -
2.7	40562812TA -
3.10	40712813TA -
4.11	40562820TA -
4.12	40632820SA -
4.14	40802820TA -
4.15	40562820UA -
5.18	40712830SA -
5.21	40802830TA -
5.22	40632830UA -

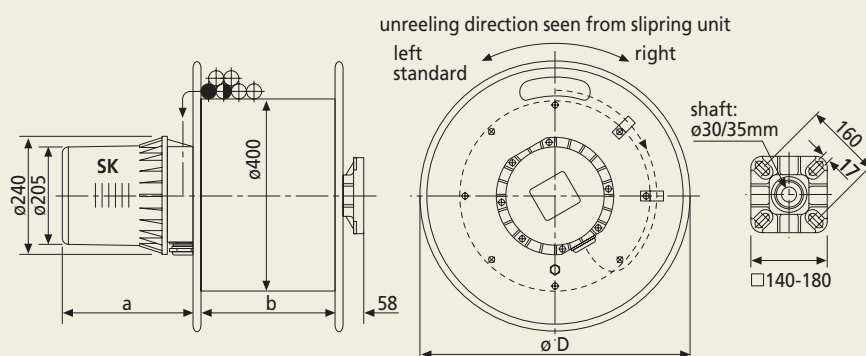

Spring-body	b	Mod. shaft ( $\phi$ )	Turns (work)	$n_v$	$n_r$	Z (daN)	Fe (daN)	Item-Nr.
Spring-body 40..2810TA	280mm	35	17	2,5	1,5	24	20	A01-C10TA28-0
Spring-body 40..2810SA	280mm	35	20	3,5	1,5	15	13	A01-C10SA28-0
Spring-body 40..2810UA	280mm	35	13	2,5	1,0	46	39	A01-C10UA28-0
Spring-body 40..2812TA	280mm	35	17	2,5	1,5	48	40	A01-C12TA28-0
Spring-body 40..2813TA	280mm	35	17	2,5	1,5	72	60	A01-C20TA28-0
Spring-body 40..2820TA	280mm	30	34	5	3	24	20	A01-C10UA28-0
Spring-body 40..2820SA	280mm	30	40	7	3	15	13	A01-C20SA28-0
Spring-body 40..2820UA	280mm	30	26	5	2	46	39	A01-C20UA28-0
Spring-body 40..2830TA	280mm	30	51	7,5	4,5	24	20	A01-C30TA28-0
Spring-body 40..2830SA	280mm	30	60	10,5	4,5	15	13	A01-C30SA28-0
Spring-body 40..2830UA	280mm	30	39	7,5	3	45	39	A01-C230UA28-0

Other spring configurations upon request

Side plate (2 pcs.)	D	Item-Nr.
Side plate CLT 40-56	560mm	A04-C40-56-0Z
Side plate CLT 40-63	630mm	A04-C40-63-0Z
Side plate CLT 40-71	710mm	A04-C40-71-0Z
Side plate CLT 40-80	800mm	A04-C40-80-0Z

Spring-body	No. rings	Max. cable types	Current	Max. Volatge	a	$\phi$ Housing	PG	Item-Nr.
GSK CLT 45-04	3 x 25A + PE	4 x 2,5	50mA - 25A	415	205mm	205mm	21	A02-C450421-0
GSK CLT 45-05	4 x 25A + PE	5 x 2,5	50mA - 25A	415	205mm	205mm	21	A02-C450521-0
GSK CLT 45-07	6 x 25A + PE	7 x 2,5	50mA - 25A	415	205mm	205mm	21	A02-C450721-0
GSK CLT 45-12	11 x 25A + PE	12 x 2,5	50mA - 25A	415	295mm	205mm	21	A02-C451221-0
GSK CLT 45-18	17 x 25A + PE	18 x 2,5	50mA - 25A	415	390mm	205mm	21	A02-C451821-0
GSK CLT 02-04	3 x 50A + PE	4 x 10	50mA - 50A	500	205mm	205mm	29	A02-C020421-0
GSK CLT 02-05	4 x 50A + PE	5 x 10	50mA - 50A	500	205mm	205mm	29	A02-C020521-0
GSK CLT 03-04	3 x 90A + PE	4 x 16	50mA - 90A	500	205mm	205mm	29	A02-C030421-0
GSK CLT 03-05	4 x 90A + PE	5 x 16	50mA - 90A	500	205mm	205mm	29	A02-C030521-0
GSK CLT 98-24	23 x 25A + PE	24 x 2,5	30mA - 25A	500	295mm	205mm	29	A02-C902421-0

Deviating other types upon request

Mounting flange	Item-Nr.
Mounting flange	AA4-A12060-0A
Mounting flange with roll back lock	A09-D04050-0Z

Accessories	Item-Nr.
Rigid mounting base	AA9-L04651-0Z
Guidearm short b= 280	A06-A4080280Z

Head Office

**Cavotec MSL Holdings Ltd.**

Cavotec MSL is listed on the **NZX**

Corporate Office

**Cavotec (Swiss) SA**

Via Serafino Balestra 27  
CH-6900 Lugano, Switzerland

*We are present in*

Argentina	Luxemburg
Australia	Malaysia
Belgium	Mexico
Brazil	The Netherlands
Canada	New Zealand
Chile	Norway
China	Russia
Denmark	Saudi Arabia
Egypt	Singapore
Finland	South Africa
France	Sweden
Germany	Switzerland
Hong Kong	Taiwan
India	Turkey
Indonesia	Qatar
Ireland	U.A.E.
Italy	U.K.
Japan	U.S.A.
Korea	

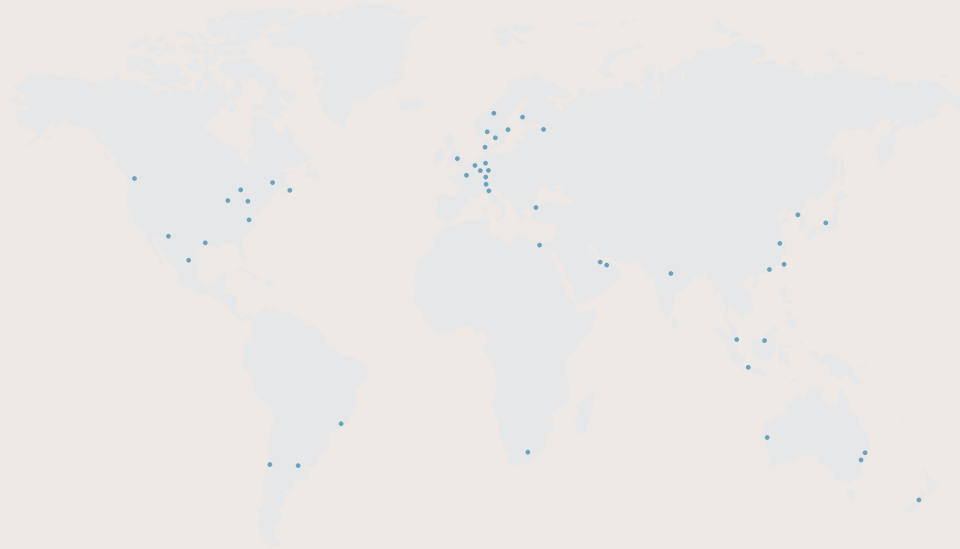

For more information please visit our website [www.cavotec.com](http://www.cavotec.com)  
or contact us directly at [info@cavotec.com](mailto:info@cavotec.com)